

TTP-225 / TTP-323 Series

**THERMAL TRANSFER / DIRECT THERMAL
BAR CODE PRINTER**

**SERVICE
MANUAL**

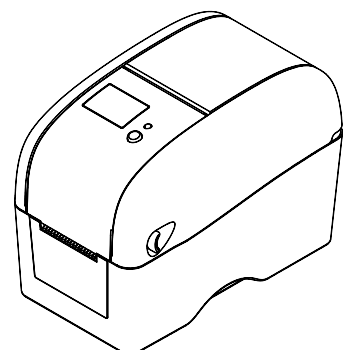

TABLE OF CONTENT

1. OVERVIEW	1
1.1 Front View	1
1.2 Interior View	2
1.3 Rear View.....	3
2. ELECTRONICS.....	5
2.1 Summary of Board Connectors.....	5
2.2 Pin Configuration.....	10
3. MECHANISM	12
3.1 Replacing Feed Button PCB/ Feed Button PCB with LCD Module (Factory option).....	12
3.2 Replacing the Main Board and RS-232/ Ethernet (Option) interface board	14
3.3 Replacing the Platen Roller Assembly.....	17
3.4 Replacing the Print Head Assembly.....	19
3.5 Replacing the Stepping Motor	20
3.7 Peel-off Module Installation (Option)	21
3.8 Cutter Module Installation (Option).....	23
4. TROUBLESHOOTING	25
4.1 LED Status.....	25
4.2 Print Quality	26
4.3 LCD display (Factory option).....	28
5. MAINTENANCE	29
UPDATE HISTORY	31

1. OVERVIEW

1.1 Front View



1.2 Interior View

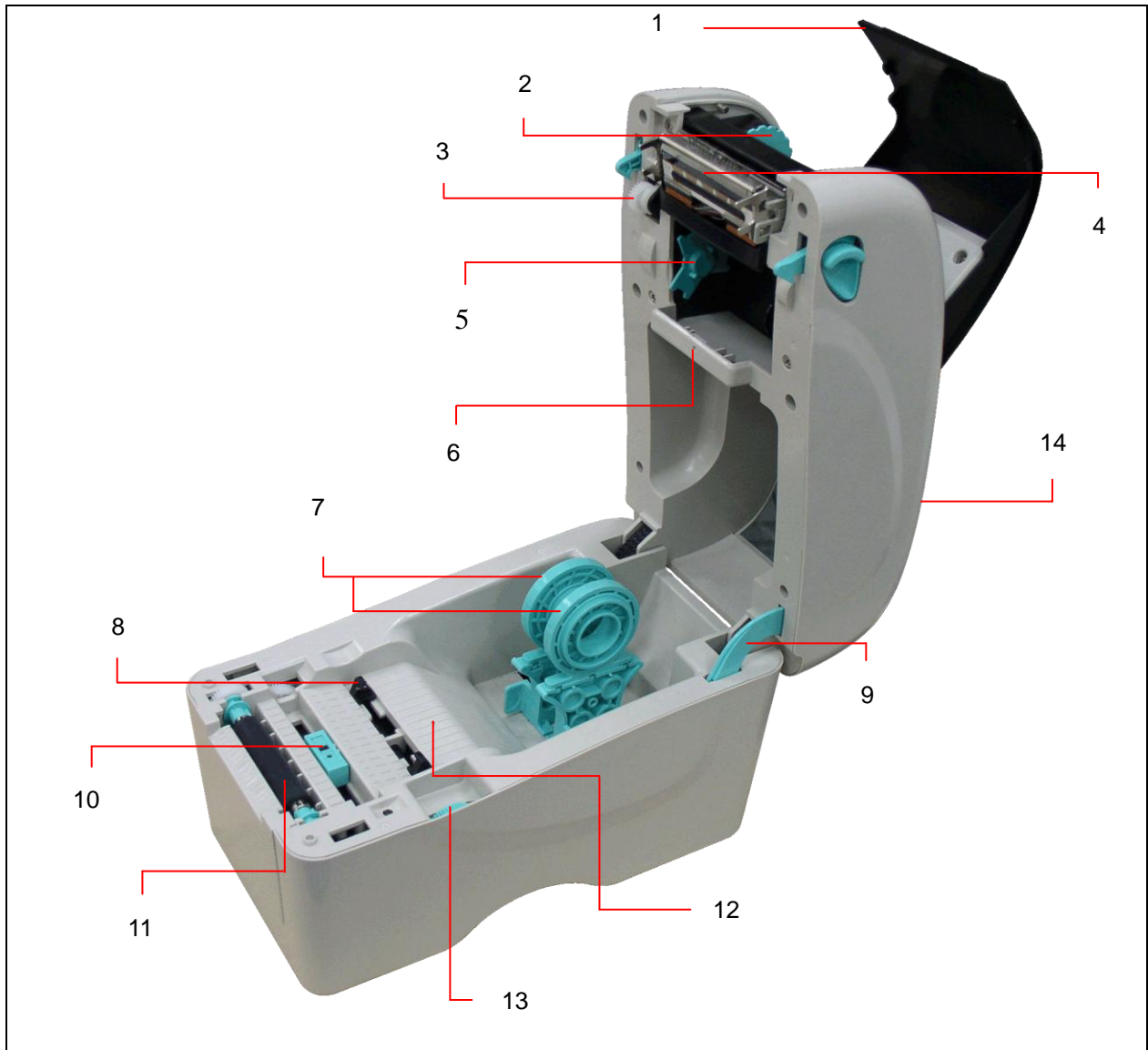

1. Ribbon access cover
2. Ribbon rewind hub
3. Ribbon rewind gear
4. Print head
5. Ribbon supply hub
6. Gap sensor (receiver)
7. Media holders
8. Media guide
9. Top cover support
10. Black mark sensor
11. Platen roller
12. Gap sensor (transmitter)
13. Media guide adjuster knob
14. Top cover

1.3 Rear View

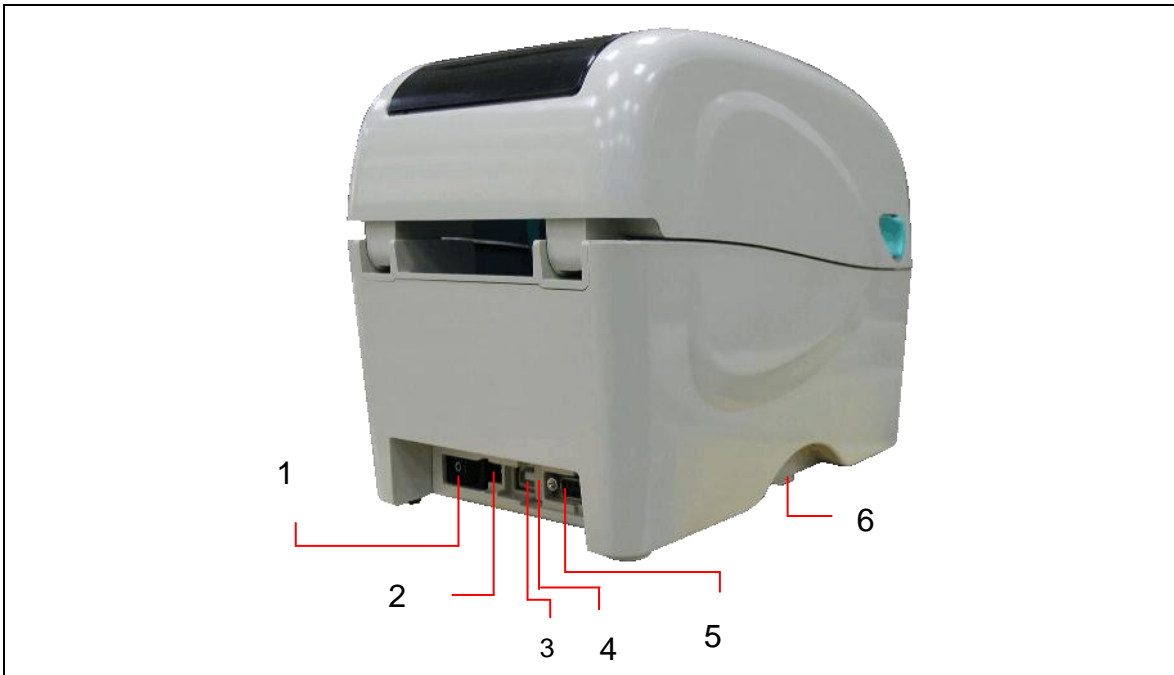

1. Power switch
2. Power jack socket
3. USB interface
4. USB host (Factory option)
5. RS-232C interface / Ethernet interface (Option)
6. SD card socket

Note:

* The interface picture is for reference only. Please refer to the product specification for the interface availability.

*** Recommended MicroSD card specification.**

SD card spec	SD card capacity	Approved SD card manufacturer
V1.0, V1.1	MicroSD 128 MB	Transcend, Panasonic
V1.0, V1.1	MicroSD 256 MB	Transcend, Panasonic
V1.0, V1.1	MicroSD 512 MB	Transcend, Panasonic
V1.0, V1.1	MicroSD 1 GB	Transcend, Panasonic
V2.0 SDHC CLASS 6	MicroSD 4 GB	Transcend

- The DOS FAT file system is supported for the SD card.
- Folders/files stored in the SD card should be in the 8.3 filename format

2. ELECTRONICS

2.1 Summary of Board Connectors

Main board

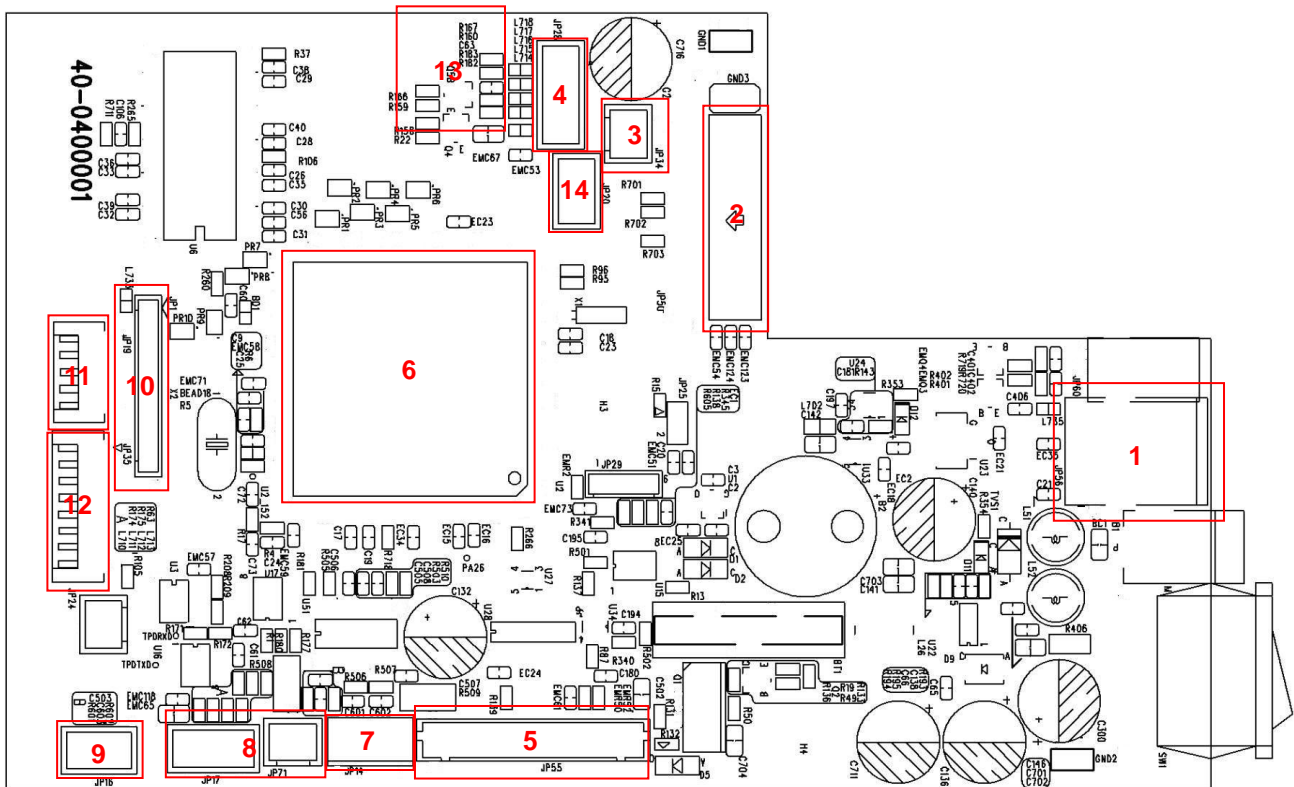

Connector	Description	Remark		
1	USB connector	JP56		
2	RS-232 interface board connector	JP50		
3	Gap sensor receiver connector	JP34		
		Pin	Description	Voltage
		1	Power	3.3V
2	GAP sensor receiver AD	0~3.3V		

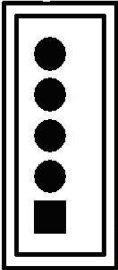
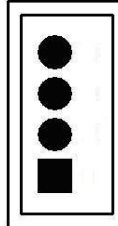
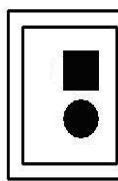
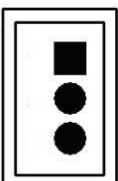
4	Feed key and LED connector	JP28																
	 <table border="1"> <thead> <tr> <th>Pin</th> <th>Description</th> <th>Voltage</th> </tr> </thead> <tbody> <tr> <td>1</td> <td>Power</td> <td>3.3V</td> </tr> <tr> <td>2</td> <td>LED green</td> <td>LED light on: 1.1~1.4V LED light off: 1.6~1.9V</td> </tr> <tr> <td>3</td> <td>LED red</td> <td>LED light on: 1.4~1.7V LED light off: 1.8~2.1V</td> </tr> <tr> <td>4</td> <td>Feed switch</td> <td>0V: Push key 3.3V: Stand-by</td> </tr> <tr> <td>5</td> <td>GND</td> <td>0V</td> </tr> </tbody> </table>	Pin	Description	Voltage	1	Power	3.3V	2	LED green	LED light on: 1.1~1.4V LED light off: 1.6~1.9V	3	LED red	LED light on: 1.4~1.7V LED light off: 1.8~2.1V	4	Feed switch	0V: Push key 3.3V: Stand-by	5	GND
Pin	Description	Voltage																
1	Power	3.3V																
2	LED green	LED light on: 1.1~1.4V LED light off: 1.6~1.9V																
3	LED red	LED light on: 1.4~1.7V LED light off: 1.8~2.1V																
4	Feed switch	0V: Push key 3.3V: Stand-by																
5	GND	0V																
5	Print head connector	JP55																
6	Micro processor																	
7	Stepping motor connector	JP14																
8	Black mark sensor connector	JP17																
	 <table border="1"> <thead> <tr> <th>Pin</th> <th>Description</th> <th>Voltage</th> </tr> </thead> <tbody> <tr> <td>1</td> <td>Power</td> <td>3.3V</td> </tr> <tr> <td>2</td> <td>Gap sensor emitter</td> <td>Emitter on : 2.1~2.3V Emitter off: 3.3V</td> </tr> <tr> <td>3</td> <td>Black mark sensor emitter</td> <td>Emitter on : 2.1~2.3V Emitter off: 2.6~2.8V</td> </tr> <tr> <td>4</td> <td>Black mark sensor receiver AD</td> <td>0~3.3V</td> </tr> </tbody> </table>	Pin	Description	Voltage	1	Power	3.3V	2	Gap sensor emitter	Emitter on : 2.1~2.3V Emitter off: 3.3V	3	Black mark sensor emitter	Emitter on : 2.1~2.3V Emitter off: 2.6~2.8V	4	Black mark sensor receiver AD	0~3.3V		
	Pin	Description	Voltage															
1	Power	3.3V																
2	Gap sensor emitter	Emitter on : 2.1~2.3V Emitter off: 3.3V																
3	Black mark sensor emitter	Emitter on : 2.1~2.3V Emitter off: 2.6~2.8V																
4	Black mark sensor receiver AD	0~3.3V																
Gap emitter connector	JP71																	
 <table border="1"> <thead> <tr> <th>Pin</th> <th>Description</th> <th>Voltage</th> </tr> </thead> <tbody> <tr> <td>1</td> <td>Power</td> <td>3.3V</td> </tr> <tr> <td>2</td> <td>Gap sensor emitter</td> <td>Emitter on : 2.1~2.3V Emitter off: 3.3V</td> </tr> </tbody> </table>	Pin	Description	Voltage	1	Power	3.3V	2	Gap sensor emitter	Emitter on : 2.1~2.3V Emitter off: 3.3V									
Pin	Description	Voltage																
1	Power	3.3V																
2	Gap sensor emitter	Emitter on : 2.1~2.3V Emitter off: 3.3V																
9	Head open sensor connector	JP16																
	 <table border="1"> <thead> <tr> <th>Pin</th> <th>Description</th> <th>Voltage</th> </tr> </thead> <tbody> <tr> <td>1</td> <td>Power</td> <td>0V to 1.2V to 0V, 10ms square wave continued</td> </tr> <tr> <td>2</td> <td>Head open sensor receiver</td> <td>Head close: 3.3V to under 1.0V to 3.3V, 10ms square wave continued Head open: 3.3V continued</td> </tr> <tr> <td>3</td> <td>GND</td> <td>0V</td> </tr> </tbody> </table>	Pin	Description	Voltage	1	Power	0V to 1.2V to 0V, 10ms square wave continued	2	Head open sensor receiver	Head close: 3.3V to under 1.0V to 3.3V, 10ms square wave continued Head open: 3.3V continued	3	GND	0V					
Pin	Description	Voltage																
1	Power	0V to 1.2V to 0V, 10ms square wave continued																
2	Head open sensor receiver	Head close: 3.3V to under 1.0V to 3.3V, 10ms square wave continued Head open: 3.3V continued																
3	GND	0V																
10	LCD connector (Option)	JP1																

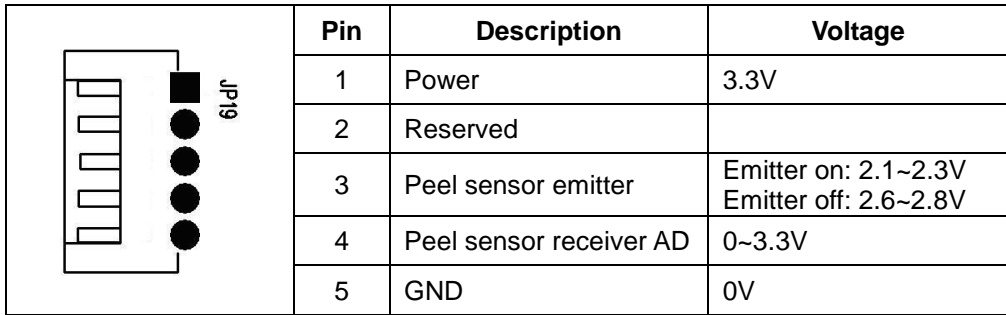
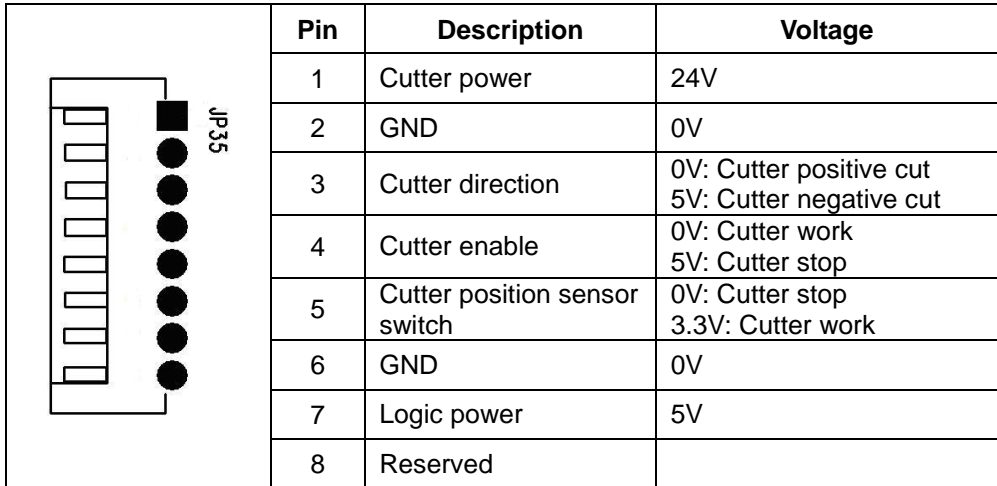
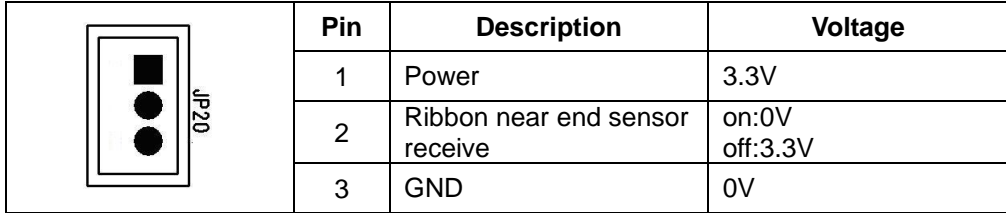
11	Peel-off sensor connector	JP19																									
	 <table border="1"> <thead> <tr> <th>Pin</th> <th>Description</th> <th>Voltage</th> </tr> </thead> <tbody> <tr> <td>1</td> <td>Power</td> <td>3.3V</td> </tr> <tr> <td>2</td> <td>Reserved</td> <td></td> </tr> <tr> <td>3</td> <td>Peel sensor emitter</td> <td>Emitter on: 2.1~2.3V Emitter off: 2.6~2.8V</td> </tr> <tr> <td>4</td> <td>Peel sensor receiver AD</td> <td>0~3.3V</td> </tr> <tr> <td>5</td> <td>GND</td> <td>0V</td> </tr> </tbody> </table>	Pin	Description	Voltage	1	Power	3.3V	2	Reserved		3	Peel sensor emitter	Emitter on: 2.1~2.3V Emitter off: 2.6~2.8V	4	Peel sensor receiver AD	0~3.3V	5	GND	0V								
Pin	Description	Voltage																									
1	Power	3.3V																									
2	Reserved																										
3	Peel sensor emitter	Emitter on: 2.1~2.3V Emitter off: 2.6~2.8V																									
4	Peel sensor receiver AD	0~3.3V																									
5	GND	0V																									
12	Cutter connector	JP35																									
	 <table border="1"> <thead> <tr> <th>Pin</th> <th>Description</th> <th>Voltage</th> </tr> </thead> <tbody> <tr> <td>1</td> <td>Cutter power</td> <td>24V</td> </tr> <tr> <td>2</td> <td>GND</td> <td>0V</td> </tr> <tr> <td>3</td> <td>Cutter direction</td> <td>0V: Cutter positive cut 5V: Cutter negative cut</td> </tr> <tr> <td>4</td> <td>Cutter enable</td> <td>0V: Cutter work 5V: Cutter stop</td> </tr> <tr> <td>5</td> <td>Cutter position sensor switch</td> <td>0V: Cutter stop 3.3V: Cutter work</td> </tr> <tr> <td>6</td> <td>GND</td> <td>0V</td> </tr> <tr> <td>7</td> <td>Logic power</td> <td>5V</td> </tr> <tr> <td>8</td> <td>Reserved</td> <td></td> </tr> </tbody> </table>	Pin	Description	Voltage	1	Cutter power	24V	2	GND	0V	3	Cutter direction	0V: Cutter positive cut 5V: Cutter negative cut	4	Cutter enable	0V: Cutter work 5V: Cutter stop	5	Cutter position sensor switch	0V: Cutter stop 3.3V: Cutter work	6	GND	0V	7	Logic power	5V	8	Reserved
Pin	Description	Voltage																									
1	Cutter power	24V																									
2	GND	0V																									
3	Cutter direction	0V: Cutter positive cut 5V: Cutter negative cut																									
4	Cutter enable	0V: Cutter work 5V: Cutter stop																									
5	Cutter position sensor switch	0V: Cutter stop 3.3V: Cutter work																									
6	GND	0V																									
7	Logic power	5V																									
8	Reserved																										
13	microSD socket	JP2																									
14	Ribbon near end sensor connector	JP20																									
	 <table border="1"> <thead> <tr> <th>Pin</th> <th>Description</th> <th>Voltage</th> </tr> </thead> <tbody> <tr> <td>1</td> <td>Power</td> <td>3.3V</td> </tr> <tr> <td>2</td> <td>Ribbon near end sensor receive</td> <td>on:0V off:3.3V</td> </tr> <tr> <td>3</td> <td>GND</td> <td>0V</td> </tr> </tbody> </table>	Pin	Description	Voltage	1	Power	3.3V	2	Ribbon near end sensor receive	on:0V off:3.3V	3	GND	0V														
Pin	Description	Voltage																									
1	Power	3.3V																									
2	Ribbon near end sensor receive	on:0V off:3.3V																									
3	GND	0V																									

Standard board

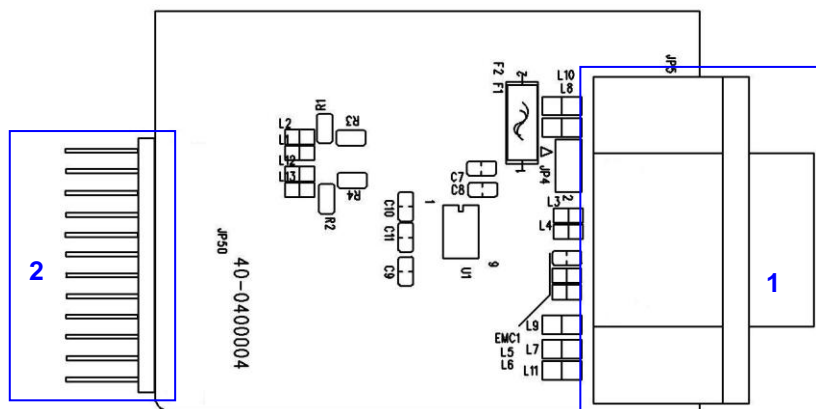

Connector	Description	Remark
1	RS232 connector	JP5
2	Main board connector	JP50

TTP-225/323 Bar Code Printer Service Manual

Option board

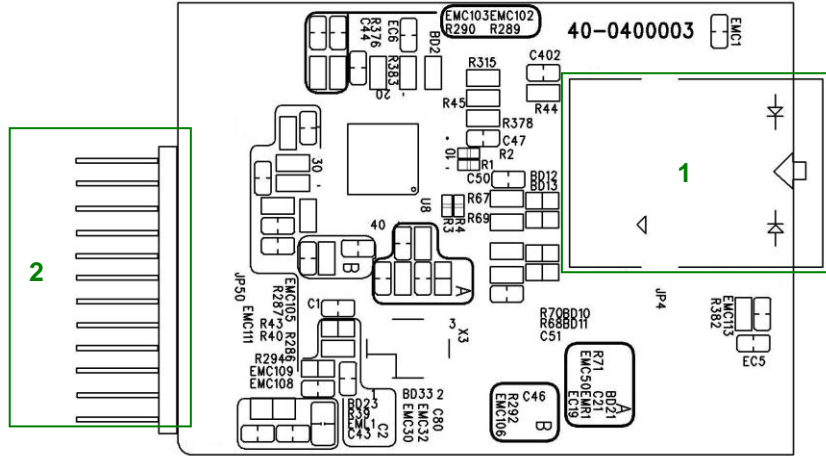

Connector	Description	Remark
1	Ethernet connector/ RJ-45	JP4
2	Main board connector	JP50

2.2 Pin Configuration

RS-232

PIN	CONFIGURATION
1	+5 V
2	TXD
3	RXD
4	CTS
5	GND
6	RTS
7	N/C
8	RTS
9	N/C

USB

	PIN	CONFIGURATION
	1	N/C
	2	D-
	3	D+
	4	GND

Ethernet (Option)

PIN	CONFIGURATION
1	Tx+
2	Tx-
3	Rx+
4	N/C
5	N/C
6	Rx-
7	N/C
8	N/C

USB host (Option)

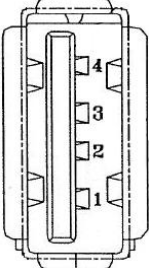
	PIN	CONFIGURATION
	1	+5V
	2	D-
	3	D+
	4	GND

3. MECHANISM

Please turn off the power switch and unplug the power adapter before replacing parts.

3.1 Replacing Feed Button PCB/ Feed Button PCB with LCD Module (Factory option)

1. Open the printer top cover by pulling the tabs located on each side towards the front of the printer, and then lift the top cover to the maximum open angle.



2. Use the screwdriver to remove the 6 screws from the top inner cover.

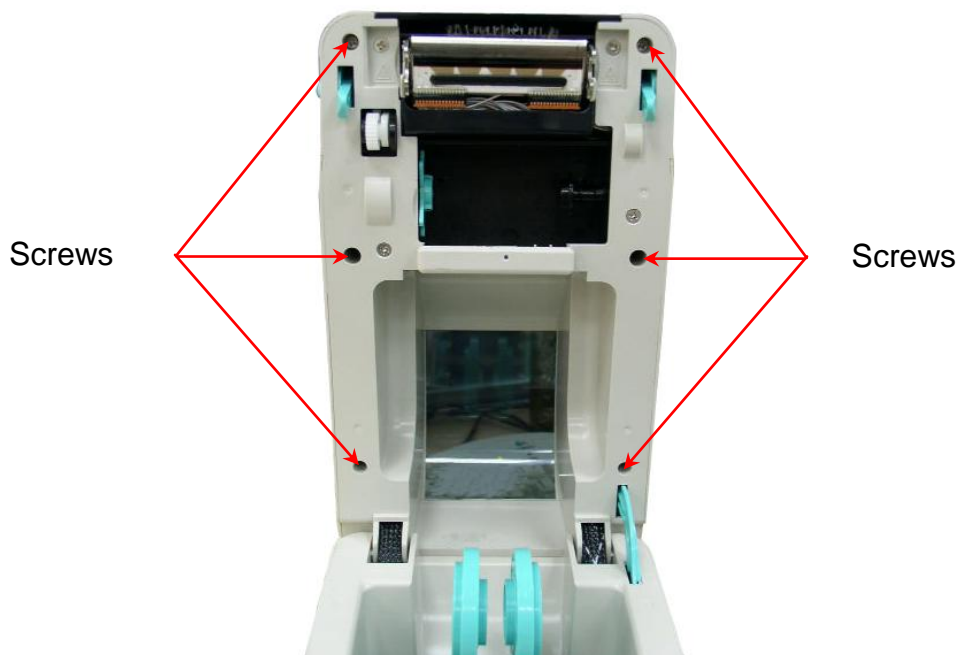

3. Remove three screws from the feed button PCB holder.

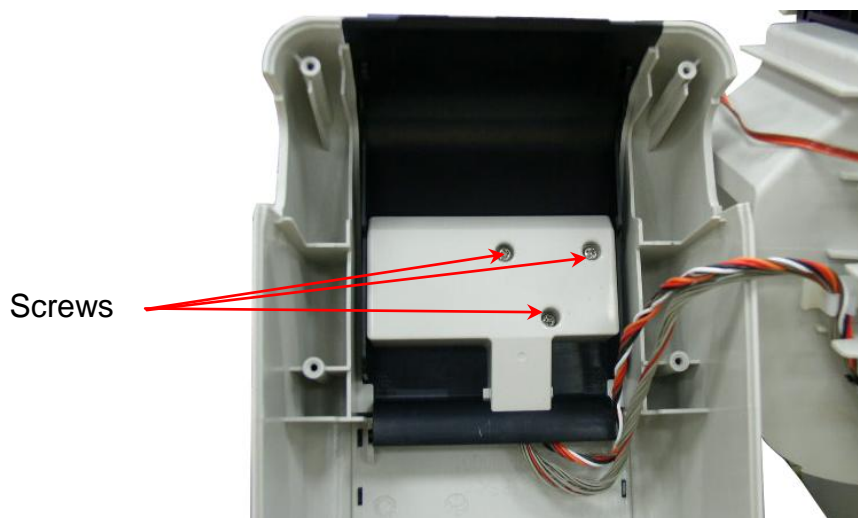

4. Disconnect the harness from the feed button PCB.

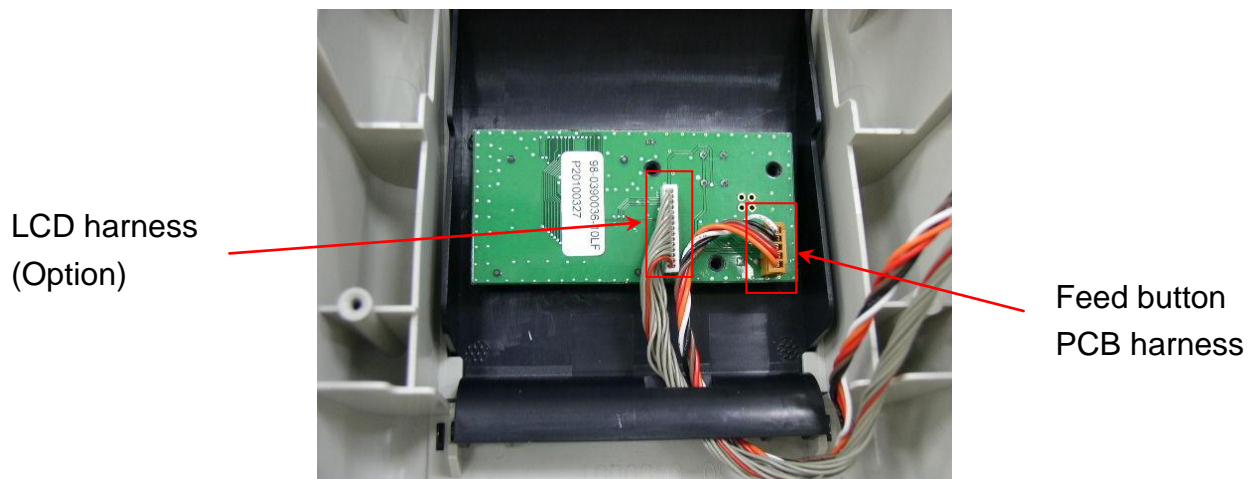

5. Replace the feed button PCB or feed button PCB with LCD module.

6. Reassemble the parts in the reverse procedure.

3.2 Replacing the Main Board and RS-232/ Ethernet (Option) interface board

1. Open the top cover and remove the lower front cover.

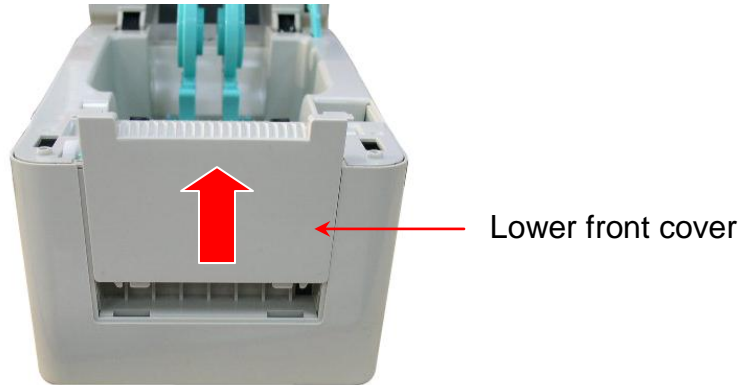

2. Close the top cover. Then turn the printer upside down and use the screwdriver to remove six screws from lower cover.

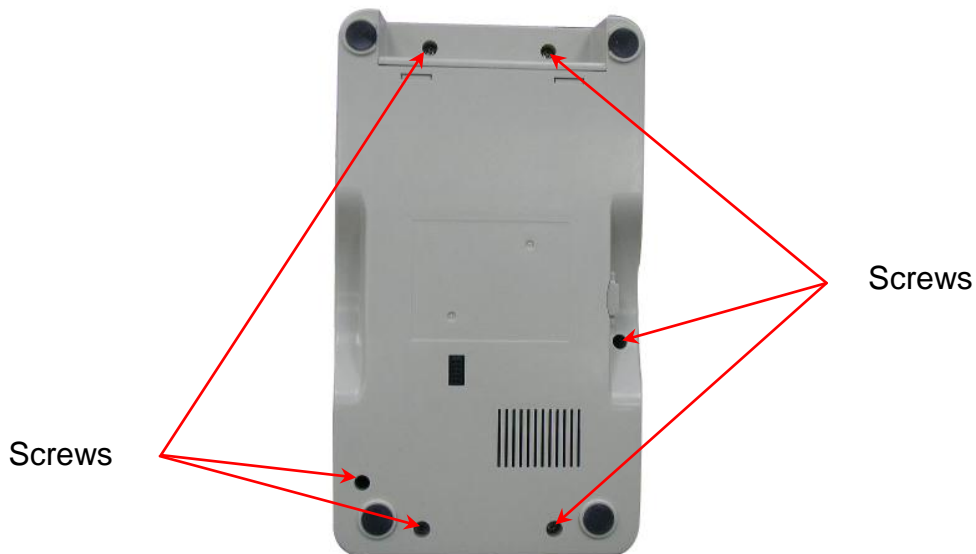

3. Remove the lower cover.



4. Remove 3 screws from the main board and RS-232/Ethernet interface board.

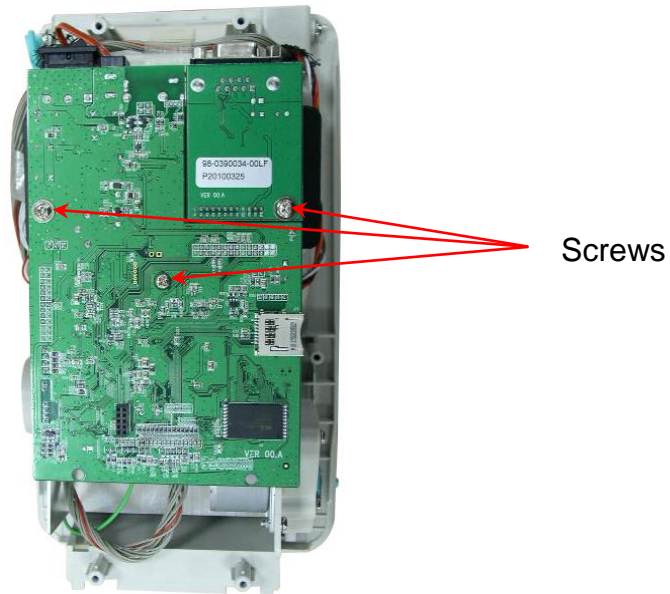

5. Disconnect all connectors from the main board.
6. Remove/Replace the main board and RS-232/Ethernet interface board.

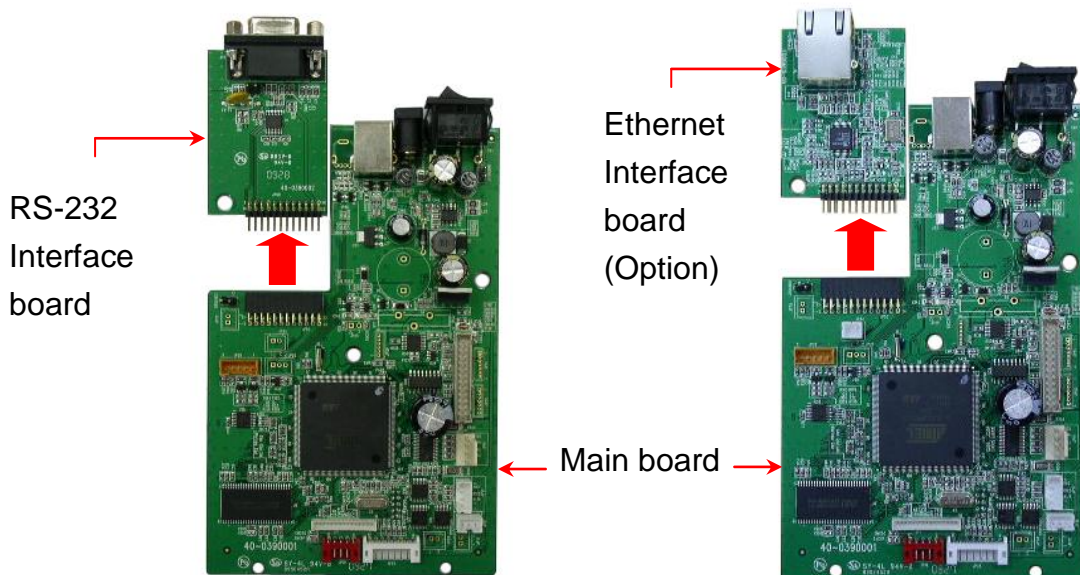

7. Take off the interface plate from the lower cover.

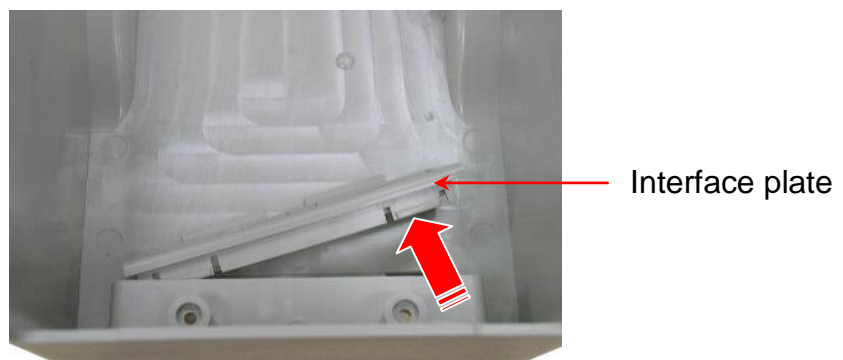

8. Reassemble the PCB, lower cover and lower front cover in reverse procedures.

9. Insert the lower side of Ethernet interface plate first then push the upper side of interface plate to install it.

Ethernet
interface plate



3.3 Replacing the Platen Roller Assembly

1. Open the printer top cover and remove the lower front cover.

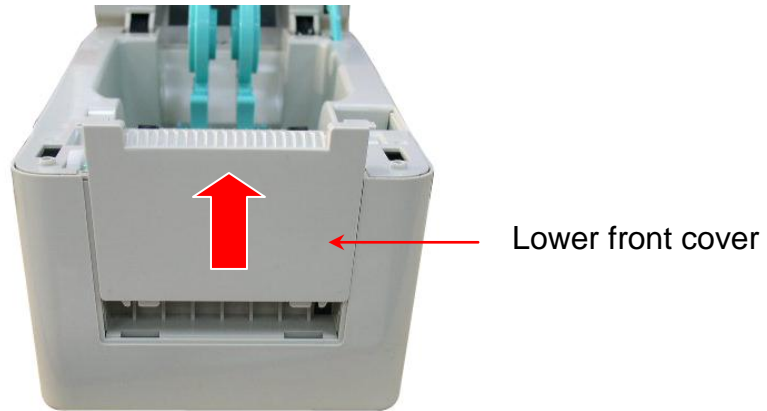

2. Disengage the platen holder tabs from the lower inner cover by pulling out the right side and left side tabs. Rotate the tabs into a horizontal position.

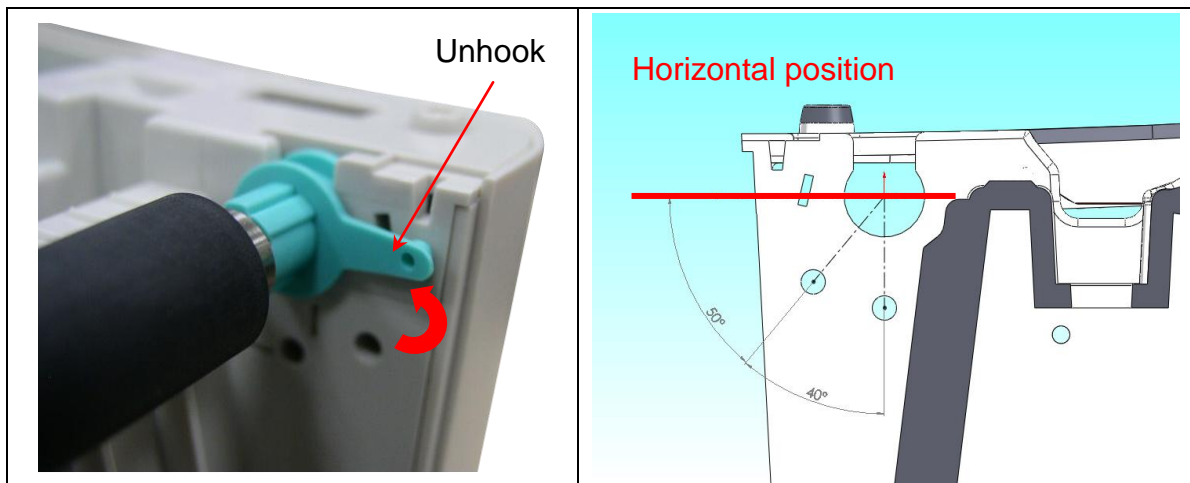

3. Take out the platen roller assembly.

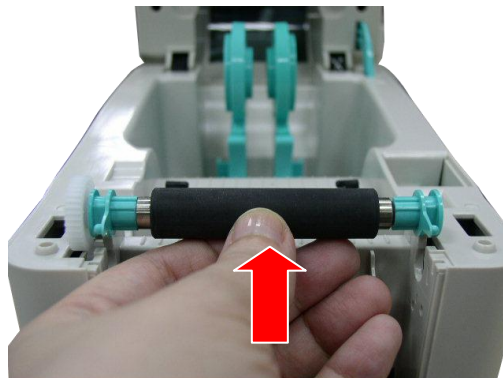

4. Replace a new platen roller assembly.

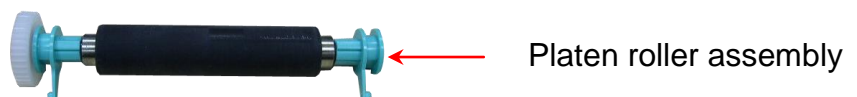

Note:

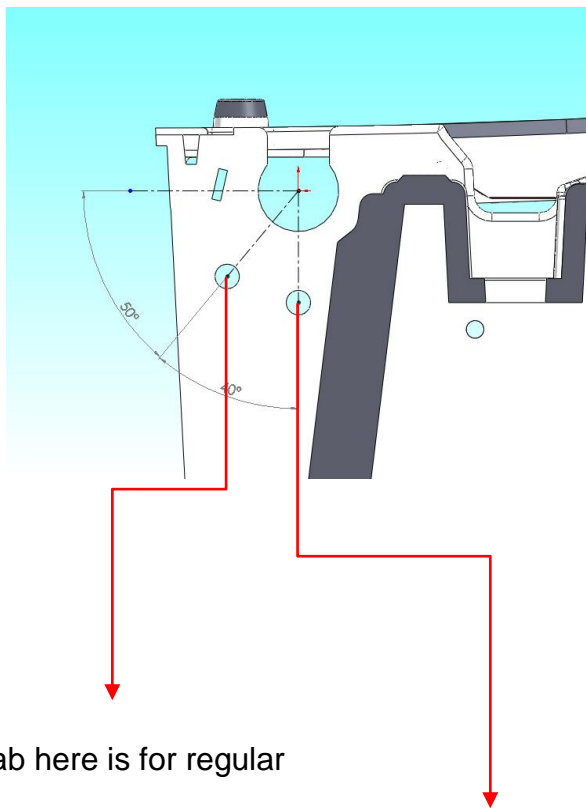

The tab here is for regular label.

The tab here is for thick label.
(Thickness is 0.19 mm)

3.4 Replacing the Print Head Assembly

1. Open the printer top cover.
2. Remove the print head cable cover.

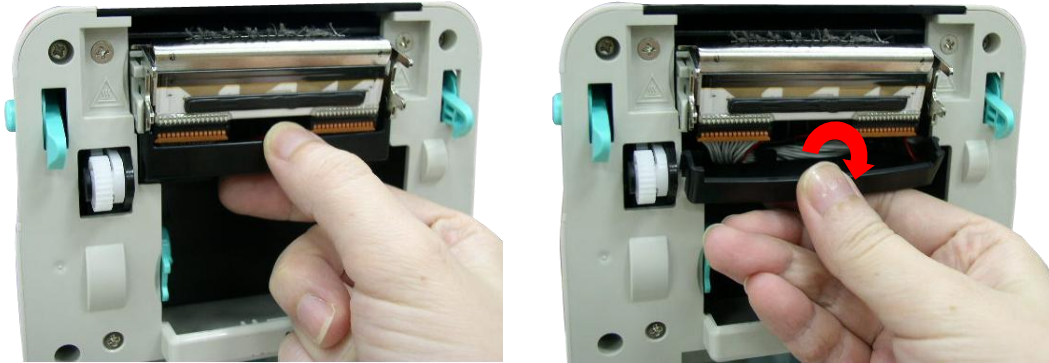

3. Press left concave of the print head bracket then pick up the print head assembly.

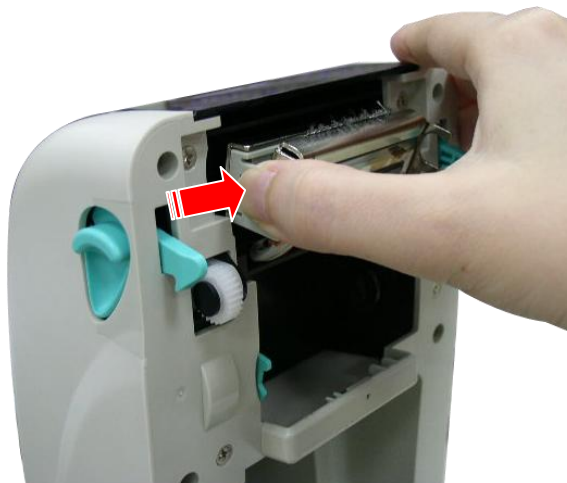

4. Disconnect the print head harness. Replace the print head assembly.

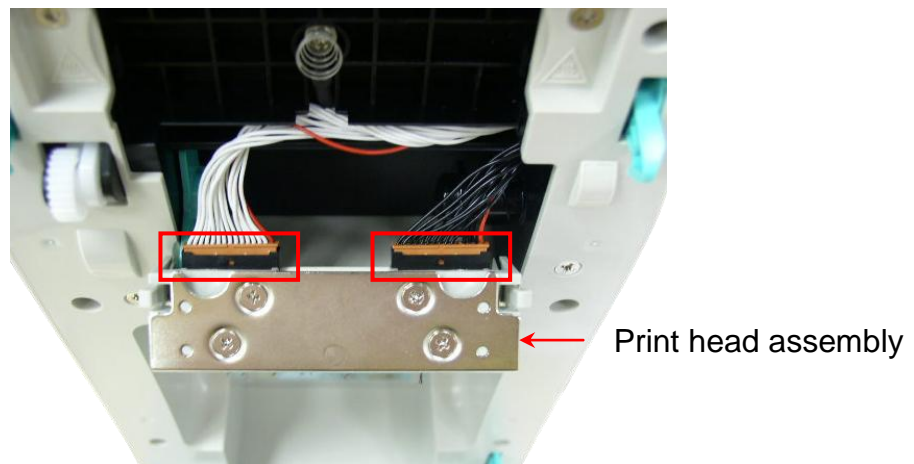

4. Reassemble the parts in the reverse procedures.

3.5 Replacing the Stepping Motor

1. Refer to section 3.2 to remove main board and RS-232/Ethernet interface board.
2. Use the screwdriver to remove 2 screws.

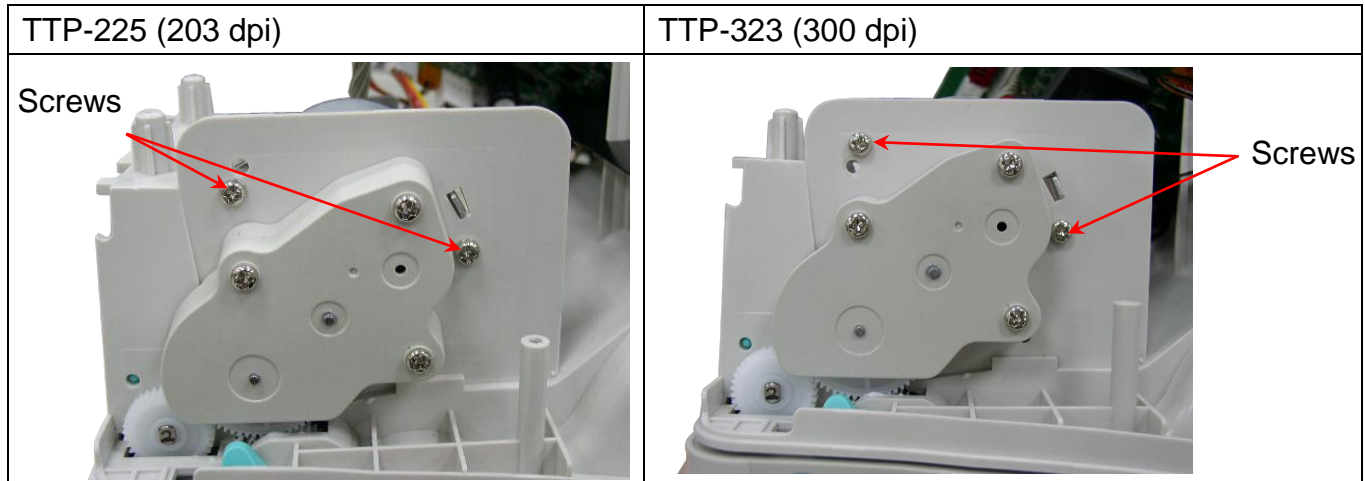

3. Remove/Replace the stepping motor.
4. Reassemble the parts in the reverse procedures.

3.7 Peel-off Module Installation (Option)

1. Refer to section 3.2 to remove the lower cover.
2. Thread the 5-pin peel-off module harness through the front slot of lower inner cover. Plug in the peel-off module harness connector to the 5-pin red socket on the main board.

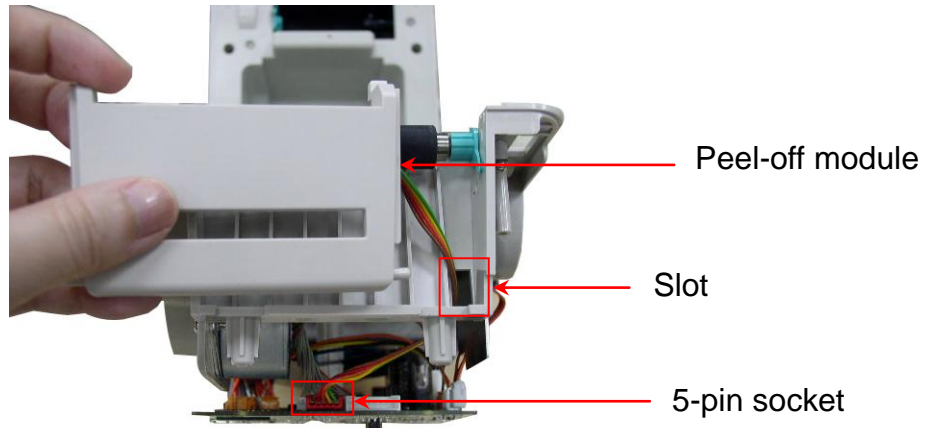

3. Embed the tenons into the both sides mortise of lower inner cover.

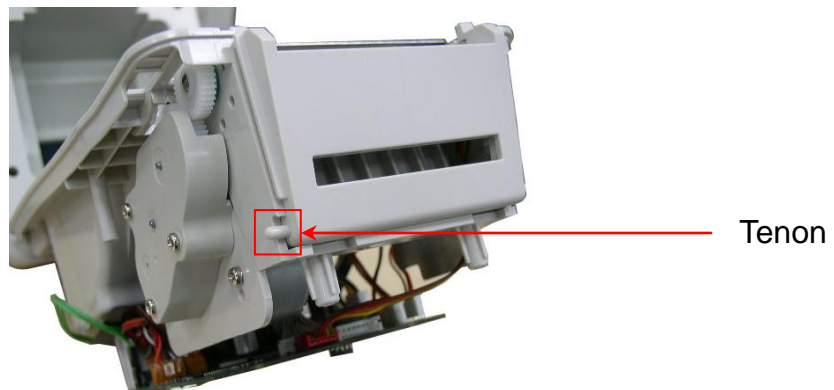

4. Take off the interface plate from the lower cover.

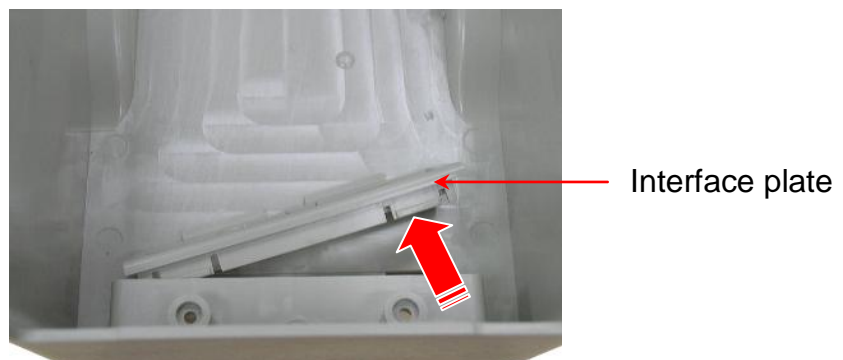

5. Then, put back the lower inner cover. Fasten 4 screws and Insert the interface plate.



6. Insert the lower side of interface plate first then push the upper side of interface plate to install it.



7. Open the top cover and peel-off cover. Install the peel-off bar into the both slots of lower inner cover. Install the right side with spring first.

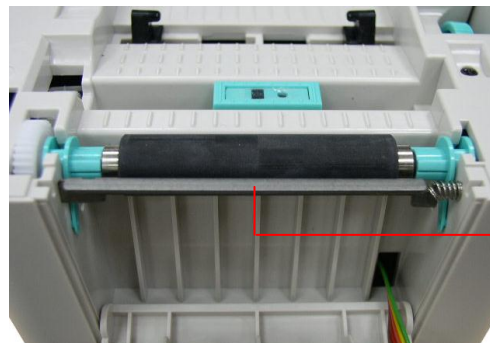

Peel-off bar

8. Place the printer in the flat and secured desktop for media loading and printing.

3.8 Cutter Module Installation (Option)

1. Refer to section 3.2 to remove the lower cover.
2. Thread the cutter module 8-pin harness through the front slot of lower inner cover. Connect the cutter module harness connector to the 8-pin white socket on the printer main board.

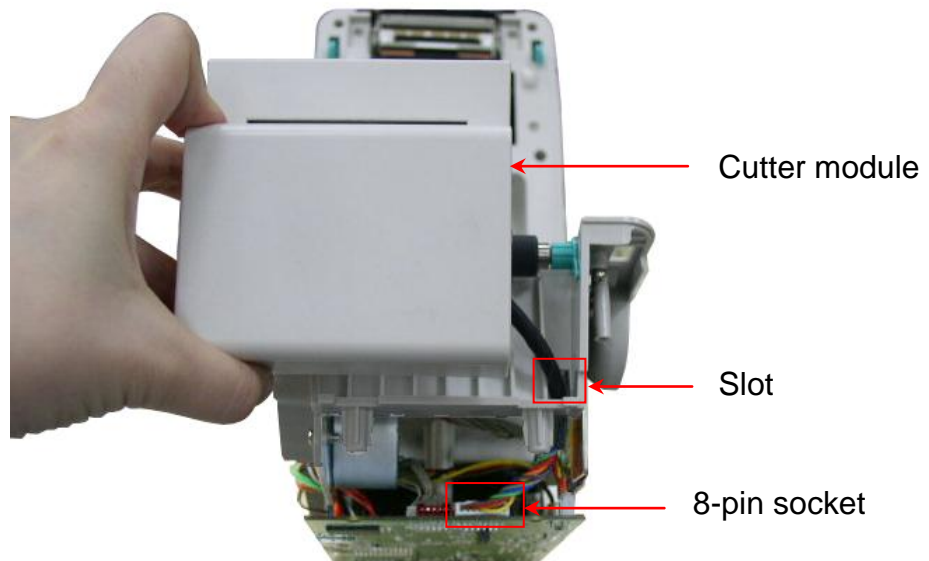

3. Take off the interface plate from the lower cover.

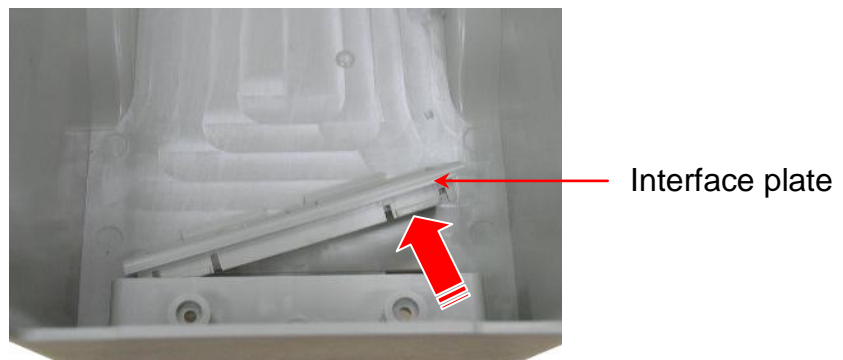

4. Then, put back the lower inner cover. Place the cutter module into the both sides notches of lower inner cover, then push cutter to lock into the lower inner cover.



5. Insert the lower side of interface plate first then push the upper side of interface plate to install it.



6. Place the printer in the flat and secured desktop for media loading and printing.

P/N:

4. TROUBLESHOOTING

The following guide lists the most common problems that might be encountered when operating this bar code printer. If the printer still does not function after all suggested solutions have been invoked, please contact the Customer Service Department of your purchased reseller or distributor for assistance.

4.1 LED Status

This section lists the common problems that according to the LED status and other problems you may encounter when operating the printer. Also, it provides solutions.

LED Status / Color	Printer Status	Possible Cause	Recovery Procedure
OFF	No response	No power	<ul style="list-style-type: none"> * Turn on the power switch. * Check if the green LED is lit on power supply. If it is not lit on, power supply is broken. * Check both power connections from the power cord to the power supply and from the power supply to the printer power jack if they are connected securely.
Solid Green	ON	The printer is ready to use	* No action necessary.
Green with blinking	Pause	The printer is paused	* Press the FEED button to resume for printing.
Red with blinking	Error	The out of label or ribbon or the printer setting is not correct	<ol style="list-style-type: none"> 1. Out of label or ribbon <ul style="list-style-type: none"> * Load a roll of label and follow the instructions in loading the media then press the FEED button to resume for printing. * Load a roll of ribbon and follow the instructions in loading the ribbon then press the FEED button to resume for printing. 2. Printer setting is not correct <ul style="list-style-type: none"> * Initialize the printer by instructions in “Power on Utility” or “Diagnostic Tool”.

Note:

Printer status can be easily shown on the Diagnostic Tool. For more information about the Diagnostic Tool, please refer to the instruction in the software CD disk.

4.2 Print Quality

Problem	Possible Cause	Recovery Procedure
Not Printing	Check if interface cable is well connected to the interface connector.	Re-connect cable to interface.
	The serial port cable pin configuration is not pin to pin connected.	Please replace the cable with pin to pin connected.
	The serial port setting is not consistent between host and printer.	Please reset the serial port setting.
	The port specified in the Windows driver is not correct.	Select the correct printer port in the driver.
	The Ethernet IP, subnet mask, gateway is not configured properly.	Configure the IP, subnet mask and gateway.
No print on the label	Label loaded not correctly.	Follow the instructions in loading the media.
Continuous feeding labels	The printer setting may go wrong.	Please do the initialization and gap/black mark calibration.
Paper Jam	Gap/black mark sensor sensitivity is not set properly (sensor sensitivity is not enough)	Calibrate the gap/black mark sensor.
	Make sure label size is set properly.	Set label size exactly as installed paper in the labeling software or program.
	Labels may be stuck inside the printer mechanism near the sensor area.	Remove the stuck label.
Poor Print Quality	Top cover is not closed properly.	Close the top cover completely and make sure the right side and left side levers are latched properly.
	Wrong power supply is connected with printer.	Check if 24V DC output is supplied by the power supply.
	Check if supply is loaded correctly.	Reload the supply.
	Check if dust or adhesives are accumulated on the print head.	Clean the print head.

TTP-225/323 Bar Code Printer Service Manual



	Check if print density is set properly.	Adjust the print density and print speed.
	Check print head test pattern if head element is damaged.	Run printer self-test and check the print head test pattern if there is dot missing in the pattern.

4.3 LCD display (Factory option)

This section lists the LCD display messages that you may encounter when operating the printer. Also, it provides solutions.

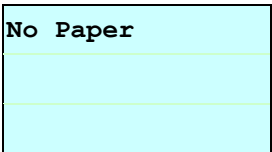
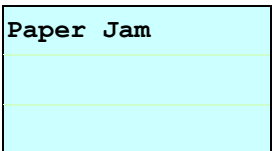
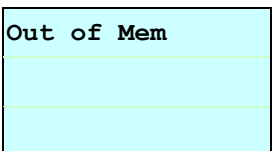
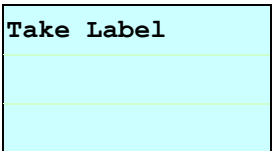
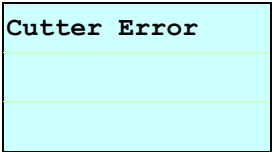
Messages	Possible Cause	Recovery Procedure
	<ul style="list-style-type: none"> * The printer top cover is open. 	<ul style="list-style-type: none"> * Please close the top cover.
	<ul style="list-style-type: none"> * Running out of label. * The label is installed incorrectly. * Gap/black mark sensor is not calibrated. 	<ul style="list-style-type: none"> * Supply a new label roll. * Please refer to the steps in user's manual to reinstall the label roll. * Calibrate the gap/black mark sensor.
	<ul style="list-style-type: none"> * Gap/black mark sensor is not set properly. * Make sure label size is set properly. * Labels may be stuck inside the printer mechanism. 	<ul style="list-style-type: none"> * Calibrate the gap/black mark sensor. * Set label size correctly.
	<ul style="list-style-type: none"> * The space of FLASH/DRAM or MicroSD card is full. 	<ul style="list-style-type: none"> * Delete unused files in the FLASH/DRAM or MicroSD card.
	<ul style="list-style-type: none"> * Peel function is enabled. Waiting user to take label away to print the next label. 	<ul style="list-style-type: none"> * Please take the label away to print the next label if peeler module is installed. * If peeler module is installed and label is been taken away, but the message remains. Please check if the peeler module connector is connected to main board properly. * If peeler module is not installed, please disable the peeler function.
	<ul style="list-style-type: none"> * Cutter jam. * There is no cutter installed on the printer. * Cutter or cutter driver circuit board is damaged. 	<ul style="list-style-type: none"> * Remove the jammed label. * Make sure the media thickness is equal or less than 0.19mm. * Replace the cutter or cutter driver circuit board.

5. MAINTENANCE

This session presents the clean tools and methods to maintain your printer.

1. Please use one of following material to clean the printer.

- Cotton swab (Head cleaner pen)
- Lint-free cloth
- Vacuum / Blower brush
- 100% ethanol

2. The cleaning process is described as following

Printer Part	Method	Interval
<p>Print Head</p>	<p>1. Always turn off the printer before cleaning the print head.</p> <p>2. Allow the print head to cool for a minimum of one minute.</p> <p>3. Use a cotton swab and 100% ethanol to clean the print head surface.</p>	<p>Clean the print head when changing a new label roll</p>
	<p>The diagram illustrates the cleaning process for the print head. It shows a hand holding a 'Head Cleaner Pen' and applying it to the 'Print Head' surface. The 'Print Head' is shown in a perspective view, with a 'Head Cleaner Pen' being used to clean the 'Element' area. An inset diagram provides a closer view of the 'Print Head' and 'Element'.</p>	
<p>Platen Roller</p>	<p>1. Turn the power off.</p> <p>2. Rotate the platen roller and wipe it thoroughly with 100% ethanol and a cotton swab, or lint-free cloth.</p>	<p>Clean the platen roller when changing a new label roll</p>
<p>Tear Bar/Peel Bar</p>	<p>Use the lint-free cloth with 100% ethanol to wipe it.</p>	<p>As needed</p>

TTP-225/323 Bar Code Printer Service Manual



Sensor	Compressed air or vacuum	Monthly
Exterior	Wipe it with water-dampened cloth	As needed
Interior	Brush or vacuum	As needed

Note:

- Do not touch printer head by hand. If you touch it careless, please use ethanol to clean it.
- Please use 100% Ethenol. DO NOT use medical alcohol, which may damage the printer head.
- Regularly clean the print head and supply sensors once change a new ribbon to keep printer performance and extend printer life.
- The maximum printing ratio per dot line is 15% for this printer. To print the full web black line, the maximum black line height is limited to 40 dots, which is 5mm for 203 DPI resolution printer.

UPDATE HISTORY

Date	Content	Editor
2011/1/25	Modify TSC address	Camille
2011/3/24	Modify section 2.2, 3.2, 3.7 and 3.8	Camille
2011/4/8	Modify section 2.2	Camille
2011/5/20	Modify section 3.3	Camille



TSC Auto ID Technology Co., Ltd.

Corporate Headquarters

9F., No.95, Minquan Rd., Xindian Dist.,
New Taipei City 23141, Taiwan (R.O.C.)

TEL: +886-2-2218-6789

FAX: +886-2-2218-5678

Web site: www.tscprinters.com

E-mail: printer_sales@tscprinters.com

tech_support@tscprinters.com

Li Ze Plant

No.35, Sec. 2, Ligong 1st Rd., Wujie Township,
Yilan County 26841, Taiwan (R.O.C.)

TEL: +886-3-990-6677

FAX: +886-3-990-5577