

TDP-245 Plus/ TDP-247/ TDP-345

DIRECT THERMAL BAR CODE PRINTER

**SERVICE
MANUAL**

1. OVERVIEW	1
1.1 Front View	1
1.2 Rear View	1
1.3. Specification	2
1.3.1. Printer (TDP-245 Plus).....	2
1.3.2. Printer (TDP-247/ TDP-345)	5
1.3.3. LED.....	8
1.3.4. Button Operation.....	9
1.4. Supply Specification	12
1.4.1. Paper	12
2. ELECTRONICS	13
2.1 Summary of Board Connectors	13
2.2 Pin Configuration	16
3. REPLACE and INSTALL IMPORTANT PARTS	18
3.1. Replacing Top Cover	18
3.2. Replacing Lower Cover and main PCB	19
3.3. Replacing Platen Assembly	21
3.4. Replacing the Stepping Motor Assembly and Stepping Motor	22
3.5. Replacing Label Guide Adjustment Knob Assembly	24
3.6. Replacing Gap/Black Mark Sensor Assembly	26
3.7. Replacing Print Head Module Assembly	27
3.8. Replacing Head Open Micro Switch	28
3.9. Replacing Feed Button and Feed Button PCB	29
3.10. Install SD Memory Card	30
3.11. Peel-Off Installation (Option) Assembly	32
3.11.1 Loading Label for Peel-off Mode (Option)	34
3.12. Cutter Module Installation (Option)	36
3.12.1 Loading Label in Cutter Mode	39
3.13 Internal Ethernet Interface Installation (Option)	40
4. POWER ON UTILITIES	42
4.1. Gap/Black Mark Sensor Calibration	42
4.2. Gap/Black Mark Sensor Calibration ; Self-test ; Dump mode	43
4.3 Printer Initialization	46
4.4 Black Mark Sensor Calibration	47
4.5 Gap Sensor Calibration	47
4.6 Skip AUTO.BAS	47
5. GAP AND BLACK MARK SENSOR SELECTION	48
6. DIAGNOSTIC TOOL	49
6.1 Start the Diagnostic Tool	49

6.2 Printer Function (Calibrate sensor, Ethernet setup, RTC setup.....)	50
7. TROUBLESHOOTING.....	51
8. MAINTENANCE.....	54
UPDATE HISTORY	56

1. OVERVIEW

1.1 Front View

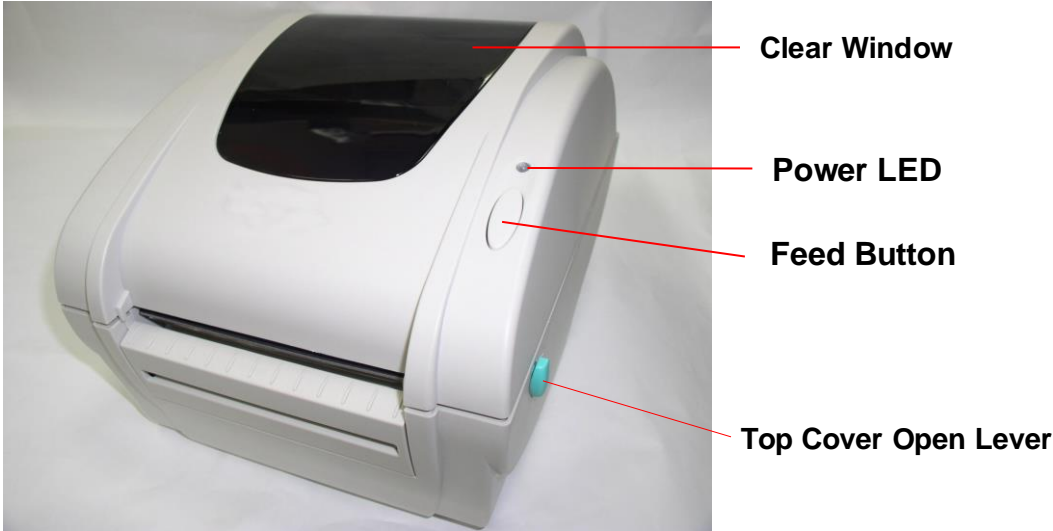

1.2 Rear View

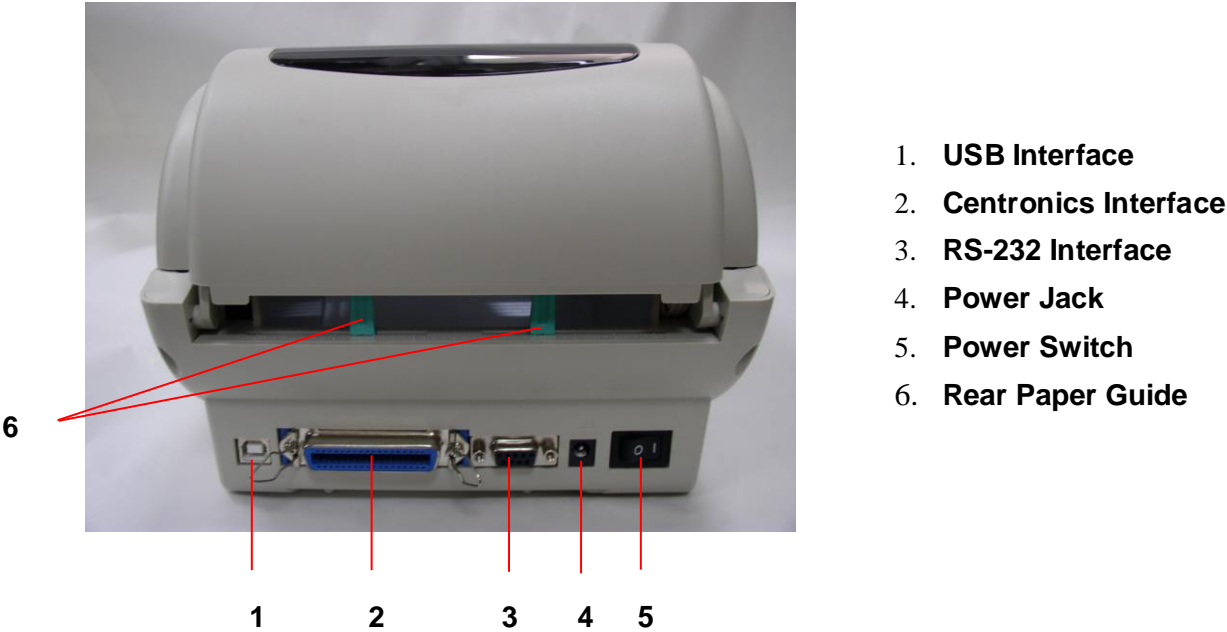

1.3. Specification

1.3.1. Printer (TDP-245 Plus)

Item \ Printer model	TDP-245 Plus
Resolution	203 DPI
Printing method	Direct Thermal
Print speed	2, 3, 4, 5 ips. 2, 3 ips for peel model
Max. print width	108 mm (4.25")
Max. print length	2286mm (90")
Enclosure	Double-walled plastic
Physical dimension	240mm (L) x 200mm (W) x 164mm (H)
Label roll capacity	5" OD
Processor	32-bit RISC high performance processor
Memory	<ul style="list-style-type: none"> ■ 2MB Flash memory ■ 8MB DRAM ■ SD card slot for memory expansion
Interface	<ul style="list-style-type: none"> ■ RS-232 (max. 115200 bps) ■ Centronics ■ USB 2.0 (Full speed mode)
Power	External universal switching power supply <ul style="list-style-type: none"> ■ Input: AC 100-240V ■ Output: DC 24V 3.75A
Operation switch, button	One power switch & feed button
Sensors	<ul style="list-style-type: none"> ■ Gap transmissive sensor (offset 6 mm from center) ■ Black mark reflective sensor (position adjustable) ■ Head open
Internal font	<ul style="list-style-type: none"> ■ 8 alpha-numeric bitmap fonts ■ One Monotype Imaging® CG Triumvirate Bold Condensed scalable font

Code Page	<ul style="list-style-type: none"> ■ Codepage 437 (English - US) ■ Codepage 850 (Latin 1) ■ Codepage 852 (Latin 2) ■ Codepage 860 (Portuguese) ■ Codepage 863 (French Canadian) ■ Codepage 865 (Nordic) ■ Codepage 857 (Turkish) ■ Codepage 861 (Iceland) ■ Codepage 1250 (Latin 2) ■ Codepage 1251 (Cyrillic) ■ Codepage 1252 (Latin 1) ■ Codepage 1253 (Greek) ■ Codepage 1254 (Turkish) ■ Codepage 1257 (Baltic) ■ Codepage 1258 (Vietnam) ■ ISO-8859-1: Latin-1 (Western European) ■ ISO-8859-2: Latin-2 (Central European) ■ ISO-8859-3: Latin-3 (South European) ■ ISO-8859-4: Latin-4 (North European) ■ ISO-8859-5: Cyrillic ■ ISO-8859-7: Greek ■ ISO-8859-9: Turkish ■ ISO-8859-10: Nordic ■ ISO-8859-15: Latin9
Bar code	<p>1D bar code Code 39, Code 93, Code128UCC, Code128 subset A, B, C, Codabar, Interleave 2 of 5, EAN-8, EAN-13, EAN-128, UPC-A, UPC-E, EAN and UPC 2(5) digits add-on, MSI, PLESSEY, POSTNET, China POST</p> <p>2D bar code PDF-417, Maxicode, DataMatrix, QR code</p>
Font & barcode rotation	0, 90, 180,270 degrees
Command set	TSPL-EZ
Media type	Continuous, die-cut, black mark, fan-fold, notch
Media wound type	Outside wound
Media width	20~112mm (0.78" ~ 4.4")

Media thickness	0.06~0.19 mm (2.3~7.4 mil), max. 150g/m ²
Media core diameter	25.4~76.2 mm (1"~3")
Label length	Min. 10 mm (0.4")
Label length (peeler mode)	25.4~152.4 mm (1"~6")
Label length (cutter mode)	25.4~2286 mm (1"~90")
Gap height	Min. 2 mm
Black mark height	Min. 2 mm
Black mark width	Min. 8 mm (0.31")
Printout bias	Vertical: 1 mm max. Horizontal: 1 mm max.
Environment condition	Operation: 5~40°C, 25~85% non-condensing Storage: -40~60°C, 10~90% non-condensing
Safety regulation	FCC Class B, CE Class B, C-Tick Class B, UL, CUL, TÜV/GS, CCC
Accessories	<ul style="list-style-type: none"> ■ BarTender UltraLite CD disk ■ Quick start guide ■ USB port cable ■ External universal switching power supply ■ Power Cord ■ Label Spindle, fixing tab x2, 1.5" core adapter x2
Reliability	<ul style="list-style-type: none"> ■ TPH: 1 million inches or 12 months, which comes first since delivery from TSC (service part) ■ Platen: 50 km (service part)
Factory option	<ul style="list-style-type: none"> ■ Real time clock ■ Main board integrated with internal Ethernet
Dealer option	<ul style="list-style-type: none"> ■ Peel off module assembly ■ Guillotine cutter <ul style="list-style-type: none"> Full cut: Paper thickness: 0.06~ 0.19mm, 500,000 cuts Partial cut: Paper thickness: 0.06~0.12mm, 500,000 cuts Paper thickness: 0.19mm 200,000 cuts ■ Internal Ethernet print server module

User option	<ul style="list-style-type: none"> ■ KP-200 ■ KU-007 plus ■ External Ethernet print server ■ External wireless (802.11b/g) print server ■ External roll mount, media OD. 214 mm (8.4") with 1" or 3" core ■ 3" core label spindle ■ Contact CCD contact scanner ■ Long range linear image bar code scanner
-------------	--

1.3.2. Printer (TDP-247/ TDP-345)

Item \ Printer model	TDP-247	TDP-345
Resolution	203 DPI	300 DPI
Printing method	Direct thermal printing	
Print speed	2, 3, 4, 5, 6, 7 ips. 2, 3 ips for peeler mode	2, 3, 4, 5 ips 2 ips for peeler mode
Max. print width	108 mm (4.25")	106 mm (4.17")
Max. print length	2286 mm (90")	1016 mm (40")
Enclosure	Double-walled plastic	
Physical dimension	240mm (L) x 200mm (W) x 164mm (H) 9.45" (L) x 7.87" (W) x 6.46" (H)	
Label roll capacity	5" OD	
Processor	32-bit RISC high performance processor	
Memory	<ul style="list-style-type: none"> ■ 4MB Flash memory ■ 8MB SDRAM ■ SD card reader for memory expansion 	
Interface	<ul style="list-style-type: none"> ■ RS-232 (max. 115200 bps) ■ Centronics ■ USB 2.0 (Full speed mode) 	
Power	External universal switching power supply <ul style="list-style-type: none"> ■ Input: AC 100-240V ■ Output: DC 24V 3.75A 	

Operation switch, button	<ul style="list-style-type: none"> ■ One power switch ■ One feed button ■ One LED (3 colors green, amber, red)
Sensors	<ul style="list-style-type: none"> ■ Gap transmissive sensor ■ Black mark reflective sensor (position adjustable) ■ Head open
Internal font	<ul style="list-style-type: none"> ■ 8 alpha-numeric bitmap fonts ■ One Monotype Imaging® CG Triumvirate Bold Condensed scalable font ■ Build-in Monotype True Type Font engine
Code Page	<ul style="list-style-type: none"> ■ Codepage 437 (English - US) ■ Codepage 850 (Latin 1) ■ Codepage 852 (Latin 2) ■ Codepage 860 (Portuguese) ■ Codepage 863 (French Canadian) ■ Codepage 865 (Nordic) ■ Codepage 857 (Turkish) ■ Codepage 950 (Traditional Chinese) ■ Codepage 936 (Simplified Chinese) ■ Codepage 932 (Japanese) ■ Codepage 949 (Korean) ■ Codepage 1250 (Latin 2) ■ Codepage 1251 (Cyrillic) ■ Codepage 1252 (Latin 1) ■ Codepage 1253 (Greek) ■ Codepage 1254 (Turkish) ■ Codepage 1257 (Baltic) ■ Codepage 1258 (Vietnam) ■ ISO-8859-1: Latin-1 (Western European) ■ ISO-8859-2: Latin-2 (Central European) ■ ISO-8859-3: Latin-3 (South European) ■ ISO-8859-4: Latin-4 (North European) ■ ISO-8859-5: Cyrillic ■ ISO-8859-7: Greek ■ ISO-8859-9: Turkish ■ ISO-8859-10: Nordic ■ ISO-8859-15: Latin9

Bar code	1D bar code Code 39, Code 93, Code128UCC, Code128 subsets A.B.C, Codabar, Interleave 2 of 5, EAN-8, EAN-13, EAN-128, UPC-A, UPC-E, EAN and UPC 2(5) digits add-on, MSI, PLESSEY, POSTNET, RSS-Stacked, RSS14, Code 11, China Post 2D bar code PDF-417, Maxicode, DataMatrix, QR code, Aztec	
Font & barcode rotation	0, 90, 180,270 degrees	
Command set	TSPL-EZ™	
Media type	Continuous, die-cut, black mark, fan-fold, notch	
Media wound type	Outside wound	
Media width	20~112mm (0.78" ~ 4.4")	
Media thickness	0.06~0.19 mm (2.3~7.4 mil), max. 150g/m ²	
Media core diameter	25.4~76.2 mm (1"~3")	
Label length	Min. 10 mm (0.4")	
Label length (peeler mode)	25.4~152.4 mm (1"~6")	
Label length (cutter mode)	25.4~2286 mm (1"~90")	25.4~1016mm (1"~40")
Gap height	Min. 2 mm	
Black mark height	Min. 2 mm	
Black mark width	Min. 8 mm (0.31")	
Printout bias	Vertical: 1 mm max. Horizontal: 1 mm max.	
Environment condition	Operation: 5~40°C (41~140°F), 25~85% non-condensing Storage: -40~60°C (-40~140°F), 10~90% non-condensing	
Safety regulation	FCC Class B, CE Class B, C-Tick Class B, UL, CUL, TÜV/Safety, CCC	

Accessories	<ul style="list-style-type: none"> ■ Windows labeling software CD disk ■ Quick start guide ■ USB cable ■ External universal switching power supply ■ Power Cord ■ Label Spindle, fixing tab x2, 1.5" core adapter x2
Reliability	<ul style="list-style-type: none"> ■ TPH: 1 million inches or 12 months, which comes first since delivery from TSC (service part) ■ Platen: 50 km (service part)
Factory option	<ul style="list-style-type: none"> ■ Real time clock ■ Main board integrated with internal Ethernet
Dealer option	<ul style="list-style-type: none"> ■ Peel off module assembly. ■ Guillotine cutter <p>Full cut: Paper thickness: 0.06~ 0.19mm, 500,000 cuts</p> <p>Partial cut: Paper thickness: 0.06~0.12mm, 500,000 cuts</p> <p>Paper thickness: 0.19mm 200,000 cuts</p>
User option	<ul style="list-style-type: none"> ■ KP-200 Plus ■ KU-007 Plus ■ HCS-200 long range linear image bar code scanner ■ Bluetooth module ■ 8.4" OD External roll mount ■ 3" core label spindle

1.3.3. LED

LED Color	Description
Green/ Solid	This illuminates that the power is on and the device is ready to use.
Green/ Flash	This illuminates that the system is downloading data from PC to memory and the printer is paused.
Amber	This illuminates that the system is clearing data from printer.
Red / Solid	This illuminates printer head open, cutter error.

Red / Flash	This illuminates a printing error, such as head open, paper empty, paper jam, or memory error etc.
-------------	--

1.3.4. Button Operation

<i>Feed</i>	<ul style="list-style-type: none"> ● Press the button when the LED is green. <ul style="list-style-type: none"> ■ It feeds the label to the beginning of the next label.
<i>Pause</i>	<ul style="list-style-type: none"> ● Press the feed button during printing. <ul style="list-style-type: none"> ■ The printing job is suspended.
<i>Gap/Black Mark Sensor Calibration</i>	<ol style="list-style-type: none"> 1. Turn off the power switch. 2. Hold on the button then turn on the power switch. 3. Release the button when LED becomes red and blinking. (Any red will do during the 5 blinks). <ul style="list-style-type: none"> ■ It will calibrate the gap/black mark sensor sensitivity. ■ The LED color will be changed as following order : Amber → red (5 blinks) → amber (5 blinks) → green (5 blinks) → green/amber (5 blinks) → red/amber (5 blinks) → solid green ■ It calibrates the sensor and measures the label length. <p>Note: Please select gap or black mark sensor by GAP or BLINE command prior to calibrate the sensor. For more information about GAP and BLINE command, please refer to TSPL2 programming manual.</p>

<p>Gap/Black Mark Sensor Calibration, Label Length Measurement, Self Test and enter Dump Mode</p>	<ol style="list-style-type: none"> 1. Turn off the power switch. 2. Hold on the button then turn on the power switch. 3. Release the button when LED becomes amber and blinking. (Any amber will do during the 5 blinks). <ul style="list-style-type: none"> ■ The LED color will be changed as following order. Amber → red (5 blinks) → amber (5 blinks) → green (5 blinks) → green/amber (5 blinks) → red/amber (5 blinks) → solid green ■ It calibrates the sensor and measures the label length and prints internal settings then enter the dump mode. <p>Note: Please select gap or black mark sensor by GAP or BLINE command prior to calibrate the sensor. For more information about GAP and BLINE command, please refer to TSPL2 programming manual.</p>
<p>Printer Initialization</p>	<ol style="list-style-type: none"> 1. Turn off the power switch. 2. Hold on the button then turn on the power switch. 3. Release the button when LED turns green after 5 amber blinks. (Any green will do during the 5 blinks). <ul style="list-style-type: none"> ■ The LED color will be changed as following: Amber → red (5 blinks) → amber (5 blinks) → green (5 blinks) → green/amber (5 blinks) → red/amber (5 blinks) → solid green ● Always do gap/black mark sensor calibration after printer initialization.
<p>Force Black Mark Sensor Calibration</p>	<ol style="list-style-type: none"> 1. Turn off the power switch. 2. Hold on the button then turn on the power switch. 3. Release the button when LED turns green/amber after 5 green blinks. (Any green/amber will do during the 5 blinks). <ul style="list-style-type: none"> ■ The LED color will be changed as following: Amber → red (5 blinks) → amber (5 blinks) → green (5 blinks) → green/amber (5 blinks) → red/amber (5 blinks) → solid green

<p>Force Gap Sensor Calibration</p>	<ol style="list-style-type: none"> 1. Turn off the power switch. 2. Hold on the button then turn on the power switch. 3. Release the button when LED turns red/amber after 5 green/amber blinks. (Any red/amber will do during the 5 blinks). <ul style="list-style-type: none"> ■ The LED color will be changed as following: Amber → red (5 blinks) → amber (5 blinks) → green (5 blinks) → green/amber (5 blinks) → red/amber (5 blinks) → solid green
<p>Skip AUTO.BAS</p>	<ol style="list-style-type: none"> 1. Turn off printer power. 2. Press the FEED button and then turn on power. 3. Release the FEED button when LED becomes solid green. <ul style="list-style-type: none"> ■ The LED color will be changed as following: Amber → red (5 blinks) → amber (5 blinks) → green (5 blinks) → green/amber (5 blinks) → red/amber (5 blinks) → solid green 4. Printer will be interrupted to run the AUTO.BAS program.

1.4. Supply Specification

1.4.1. Paper

Item	Specification
Type	Label (Continuous , Die-cut , Fan-fold)
Wound Type	Outside wound
Width	20mm ~ 112mm (0.79" ~ 4.4")
Length (Peel-off and cutter mode)	10mm ~ 1000mm (0.4" ~ 39") 25.4mm ~ 1000mm (1" ~ 39")
Thickness	0.06mm ~ 0.19mm (max. 150g/m**2)
Roll Diameter	Max. 5"
Roll Core Diameter	25.4mm ~ 76.2mm (1" ~ 3")
Gap Height	Min. 2 mm (min.)
Black Mark Height	Min. 2 mm (min.)
Black Mark Width	Min 8 mm (min.)

2. ELECTRONICS







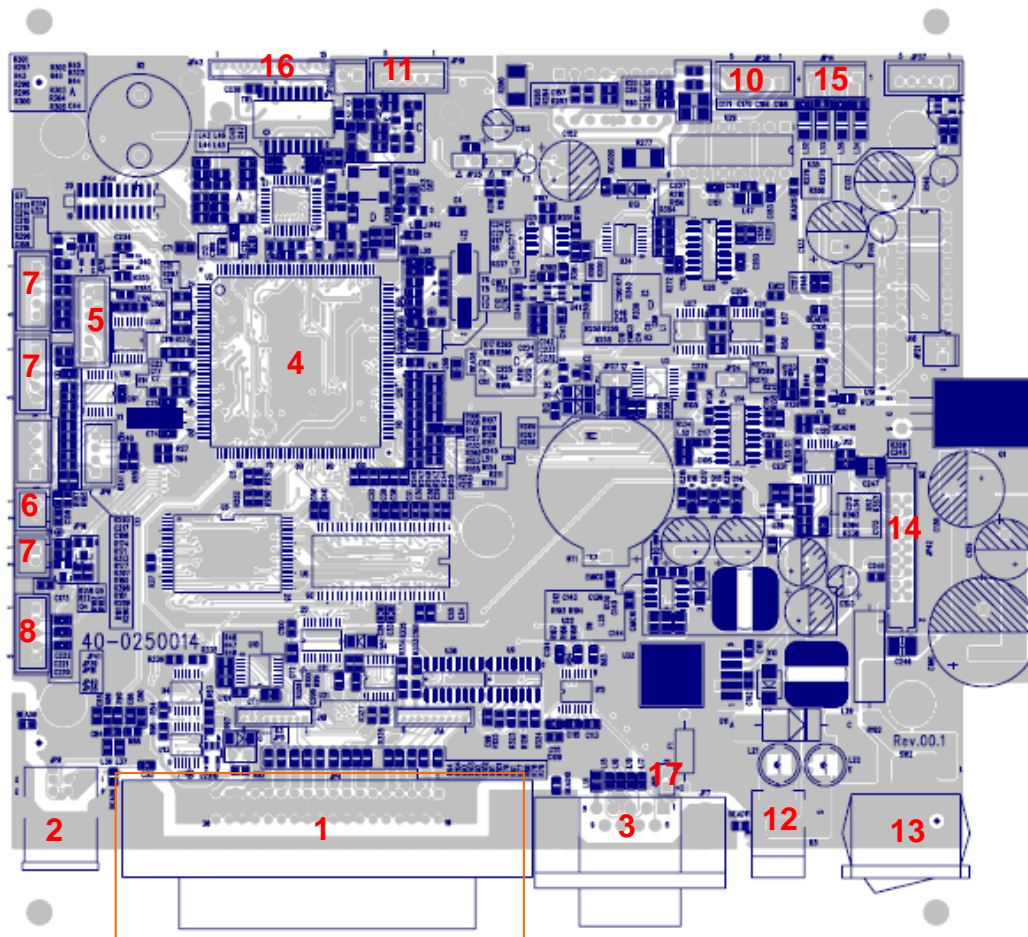



2.1 Summary of Board Connectors

Main board

Top



Connector	Description	Remark
1	Centronics port connector	JP4
2	USB connector	JP9
3	RS-232C connector	JP7
4	Micro processor	U2
5	RFID module connector	JP36
6	Head open sensor connector	JP16

	 <table border="1"> <thead> <tr> <th>Pin</th> <th>Description</th> <th>Voltage</th> </tr> </thead> <tbody> <tr> <td>1</td> <td>Head open sensor switch receiver</td> <td>0V: Head close 3.3V: Head open</td> </tr> <tr> <td>2</td> <td>GND</td> <td>0V</td> </tr> </tbody> </table>	Pin	Description	Voltage	1	Head open sensor switch receiver	0V: Head close 3.3V: Head open	2	GND	0V																																		
Pin	Description	Voltage																																										
1	Head open sensor switch receiver	0V: Head close 3.3V: Head open																																										
2	GND	0V																																										
7	<table border="1"> <tr> <td colspan="2">Gap/Black mark sensor connector</td> <td>JP39, JP41</td> </tr> <tr> <td>  <table border="1"> <thead> <tr> <th>Pin</th> <th>Description</th> <th>Voltage</th> </tr> </thead> <tbody> <tr> <td>1</td> <td>GND</td> <td>0V</td> </tr> <tr> <td>2</td> <td>Gap sensor receiver AD</td> <td>0~3.3V</td> </tr> <tr> <td>3</td> <td>Power</td> <td>3.3V</td> </tr> <tr> <td>4</td> <td>Gap sensor emitter</td> <td>Emitter on: 0.7~1.8V Emitter off: 2.4~2.7V</td> </tr> <tr> <td>5</td> <td>Gap sensor enable</td> <td>Gap switch on: 3.1~3.2V Gap switch off: 0~0.3V</td> </tr> </tbody> </table> </td> <td></td> </tr> <tr> <td>  <table border="1"> <thead> <tr> <th>Pin</th> <th>Description</th> <th>Voltage</th> </tr> </thead> <tbody> <tr> <td>1</td> <td>Reserved</td> <td></td> </tr> <tr> <td>2</td> <td>Black mark sensor enable</td> <td>Black mark switch on : 3.1~3.2V Black mark switch off: 0~0.3V</td> </tr> <tr> <td>3</td> <td>Reserved</td> <td></td> </tr> <tr> <td>4</td> <td>Black mark sensor receiver AD</td> <td>0~3.3V</td> </tr> <tr> <td>5</td> <td>GND</td> <td>0V</td> </tr> </tbody> </table> </td> <td></td> </tr> </table>	Gap/Black mark sensor connector		JP39, JP41	 <table border="1"> <thead> <tr> <th>Pin</th> <th>Description</th> <th>Voltage</th> </tr> </thead> <tbody> <tr> <td>1</td> <td>GND</td> <td>0V</td> </tr> <tr> <td>2</td> <td>Gap sensor receiver AD</td> <td>0~3.3V</td> </tr> <tr> <td>3</td> <td>Power</td> <td>3.3V</td> </tr> <tr> <td>4</td> <td>Gap sensor emitter</td> <td>Emitter on: 0.7~1.8V Emitter off: 2.4~2.7V</td> </tr> <tr> <td>5</td> <td>Gap sensor enable</td> <td>Gap switch on: 3.1~3.2V Gap switch off: 0~0.3V</td> </tr> </tbody> </table>	Pin	Description	Voltage	1	GND	0V	2	Gap sensor receiver AD	0~3.3V	3	Power	3.3V	4	Gap sensor emitter	Emitter on: 0.7~1.8V Emitter off: 2.4~2.7V	5	Gap sensor enable	Gap switch on: 3.1~3.2V Gap switch off: 0~0.3V		 <table border="1"> <thead> <tr> <th>Pin</th> <th>Description</th> <th>Voltage</th> </tr> </thead> <tbody> <tr> <td>1</td> <td>Reserved</td> <td></td> </tr> <tr> <td>2</td> <td>Black mark sensor enable</td> <td>Black mark switch on : 3.1~3.2V Black mark switch off: 0~0.3V</td> </tr> <tr> <td>3</td> <td>Reserved</td> <td></td> </tr> <tr> <td>4</td> <td>Black mark sensor receiver AD</td> <td>0~3.3V</td> </tr> <tr> <td>5</td> <td>GND</td> <td>0V</td> </tr> </tbody> </table>	Pin	Description	Voltage	1	Reserved		2	Black mark sensor enable	Black mark switch on : 3.1~3.2V Black mark switch off: 0~0.3V	3	Reserved		4	Black mark sensor receiver AD	0~3.3V	5	GND	0V	
	Gap/Black mark sensor connector		JP39, JP41																																									
 <table border="1"> <thead> <tr> <th>Pin</th> <th>Description</th> <th>Voltage</th> </tr> </thead> <tbody> <tr> <td>1</td> <td>GND</td> <td>0V</td> </tr> <tr> <td>2</td> <td>Gap sensor receiver AD</td> <td>0~3.3V</td> </tr> <tr> <td>3</td> <td>Power</td> <td>3.3V</td> </tr> <tr> <td>4</td> <td>Gap sensor emitter</td> <td>Emitter on: 0.7~1.8V Emitter off: 2.4~2.7V</td> </tr> <tr> <td>5</td> <td>Gap sensor enable</td> <td>Gap switch on: 3.1~3.2V Gap switch off: 0~0.3V</td> </tr> </tbody> </table>	Pin	Description	Voltage	1	GND	0V	2	Gap sensor receiver AD	0~3.3V	3	Power	3.3V	4	Gap sensor emitter	Emitter on: 0.7~1.8V Emitter off: 2.4~2.7V	5	Gap sensor enable	Gap switch on: 3.1~3.2V Gap switch off: 0~0.3V																										
Pin	Description	Voltage																																										
1	GND	0V																																										
2	Gap sensor receiver AD	0~3.3V																																										
3	Power	3.3V																																										
4	Gap sensor emitter	Emitter on: 0.7~1.8V Emitter off: 2.4~2.7V																																										
5	Gap sensor enable	Gap switch on: 3.1~3.2V Gap switch off: 0~0.3V																																										
 <table border="1"> <thead> <tr> <th>Pin</th> <th>Description</th> <th>Voltage</th> </tr> </thead> <tbody> <tr> <td>1</td> <td>Reserved</td> <td></td> </tr> <tr> <td>2</td> <td>Black mark sensor enable</td> <td>Black mark switch on : 3.1~3.2V Black mark switch off: 0~0.3V</td> </tr> <tr> <td>3</td> <td>Reserved</td> <td></td> </tr> <tr> <td>4</td> <td>Black mark sensor receiver AD</td> <td>0~3.3V</td> </tr> <tr> <td>5</td> <td>GND</td> <td>0V</td> </tr> </tbody> </table>	Pin	Description	Voltage	1	Reserved		2	Black mark sensor enable	Black mark switch on : 3.1~3.2V Black mark switch off: 0~0.3V	3	Reserved		4	Black mark sensor receiver AD	0~3.3V	5	GND	0V																										
Pin	Description	Voltage																																										
1	Reserved																																											
2	Black mark sensor enable	Black mark switch on : 3.1~3.2V Black mark switch off: 0~0.3V																																										
3	Reserved																																											
4	Black mark sensor receiver AD	0~3.3V																																										
5	GND	0V																																										
8	<table border="1"> <tr> <td colspan="2">LED connector</td> <td>JP28</td> </tr> <tr> <td>  <table border="1"> <thead> <tr> <th>Pin</th> <th>Description</th> <th>Voltage</th> </tr> </thead> <tbody> <tr> <td>1</td> <td>Power</td> <td>3.3V</td> </tr> <tr> <td>2</td> <td>LED green</td> <td>LED light on: 1.1~1.4V LED light off: 1.6~1.9V</td> </tr> <tr> <td>3</td> <td>LED red</td> <td>LED light on : 1.4~1.7V LED light off: 1.8~2.1V</td> </tr> <tr> <td>4</td> <td>Feed switch</td> <td>0V: Push key 3.3V: Stand-by</td> </tr> <tr> <td>5</td> <td>GND</td> <td>0V</td> </tr> </tbody> </table> </td> <td></td> </tr> </table>	LED connector		JP28	 <table border="1"> <thead> <tr> <th>Pin</th> <th>Description</th> <th>Voltage</th> </tr> </thead> <tbody> <tr> <td>1</td> <td>Power</td> <td>3.3V</td> </tr> <tr> <td>2</td> <td>LED green</td> <td>LED light on: 1.1~1.4V LED light off: 1.6~1.9V</td> </tr> <tr> <td>3</td> <td>LED red</td> <td>LED light on : 1.4~1.7V LED light off: 1.8~2.1V</td> </tr> <tr> <td>4</td> <td>Feed switch</td> <td>0V: Push key 3.3V: Stand-by</td> </tr> <tr> <td>5</td> <td>GND</td> <td>0V</td> </tr> </tbody> </table>	Pin	Description	Voltage	1	Power	3.3V	2	LED green	LED light on: 1.1~1.4V LED light off: 1.6~1.9V	3	LED red	LED light on : 1.4~1.7V LED light off: 1.8~2.1V	4	Feed switch	0V: Push key 3.3V: Stand-by	5	GND	0V																					
	LED connector		JP28																																									
 <table border="1"> <thead> <tr> <th>Pin</th> <th>Description</th> <th>Voltage</th> </tr> </thead> <tbody> <tr> <td>1</td> <td>Power</td> <td>3.3V</td> </tr> <tr> <td>2</td> <td>LED green</td> <td>LED light on: 1.1~1.4V LED light off: 1.6~1.9V</td> </tr> <tr> <td>3</td> <td>LED red</td> <td>LED light on : 1.4~1.7V LED light off: 1.8~2.1V</td> </tr> <tr> <td>4</td> <td>Feed switch</td> <td>0V: Push key 3.3V: Stand-by</td> </tr> <tr> <td>5</td> <td>GND</td> <td>0V</td> </tr> </tbody> </table>	Pin	Description	Voltage	1	Power	3.3V	2	LED green	LED light on: 1.1~1.4V LED light off: 1.6~1.9V	3	LED red	LED light on : 1.4~1.7V LED light off: 1.8~2.1V	4	Feed switch	0V: Push key 3.3V: Stand-by	5	GND	0V																										
Pin	Description	Voltage																																										
1	Power	3.3V																																										
2	LED green	LED light on: 1.1~1.4V LED light off: 1.6~1.9V																																										
3	LED red	LED light on : 1.4~1.7V LED light off: 1.8~2.1V																																										
4	Feed switch	0V: Push key 3.3V: Stand-by																																										
5	GND	0V																																										
9	5V DC connector	JP22																																										
10	Cutter connector	JP38																																										
11	Peel-off sensor connector	JP19																																										

	Pin	Description	Voltage
	1	GND	0V
	2	Peel sensor receiver AD	0~3.3V
	3	Peel sensor emitter	Emitter on : 1.0~1.2V Emitter off: 0V
	4	Power	5V
	5	Reserved	
12	Power supply output (24V DC) connector		B3
13	Power switch		SW2
14	Print head connector		JP42
15	Stepping motor connector		JP14
16	Ethernet connector (Factory option)		JP43
17	RS-232 pin 9 +5V jumper		JP6

Main board

Bottom

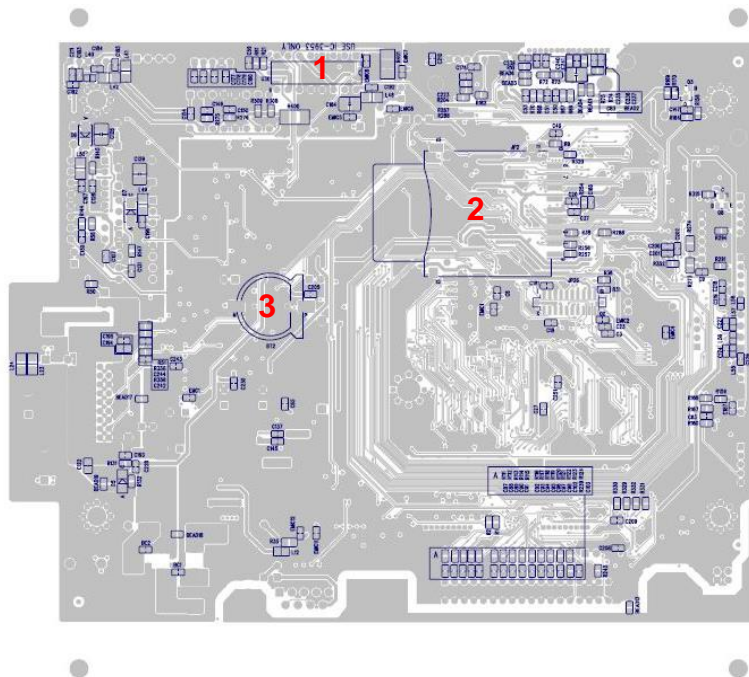

Connector	Description	Remark
1	Cutter driver IC connector	U30
2	SD card slot	JP2
3	RTC battery (Factory option)	BT2

2.2 Pin Configuration

RS-232C

PIN	CONFIGURATION
1	+5 V
2	TXD
3	RXD
4	CTS
5	GND
6	RTS
7	N/C
8	RTS
9	N/C

USB

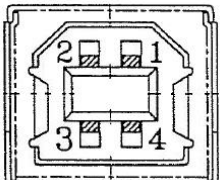
	PIN	CONFIGURATION
	1	N/C
	2	D-
	3	D+
	4	GND

Centronics

Pin	SPP Mode	Nibble	In/Out	Function
1	Strobe	N/A	In	A low on this line indicates that there are valid data at the host. When this pin is de-asserted, the +ve clock edge should be used to shift the data into the device.
2-9	Data 0-7	N/A	In	Data Bus. Single-directional.
10	Ack	N/A	Out	A low on this line indicates that there are valid data at the Device. When this pin is de-asserted, the +ve clock edge should be used to shift the data into the host.
11	Busy	N/A	Out	When in reverse direction, a high indicates data, while a low indicates a command cycle. In forward direction, it functions as PtrBusy.

12	Paper Out / End	N/A	Out	When low , device acknowledges reverse request.
13	Select	N/A	Out	Extensibility flag
14	Ground	N/A	GND	
15	No Defined	N/A	N/A	
16-17	Ground	N/A	GND	Ground
18	No Defined	N/A	N/A	
19-30	Ground	N/A	GND	Ground
31	No Defined	N/A	N/A	
32	Error / Fault	N/A	Out	A low set by the device indicates that the reverse data is available
33-35	Ground	N/A	GND	Ground
36	No Defined	N/A	N/A	

Ethernet

PIN	CONFIGURATION
1	Tx+
2	Tx-
3	Rx+
4	N/C
5	N/C
6	Rx-
7	N/C
8	N/C

3. REPLACE and INSTALL IMPORTANT PARTS

Please turn off the power switch and unplug the power adapter before replacing parts.

3.1. Replacing Top Cover

1. Open the printer **top cover** by pushing forward the **top cover open levers**.
2. Use a screwdriver to remove 6 screws on the **top inner cover**.

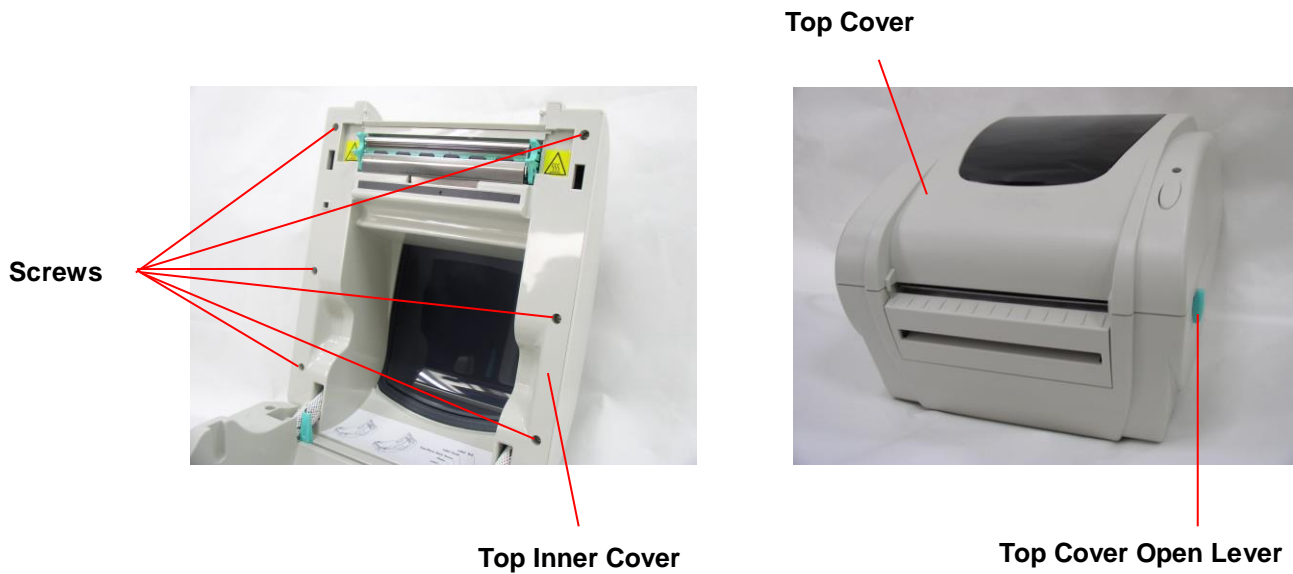

3. Remove the top cover and replace a new one.
4. Reassemble parts in reverse procedures.

3.2. Replacing Lower Cover and main PCB

1. Upside down the printer.
2. Remove 3 screws on **lower cover**.

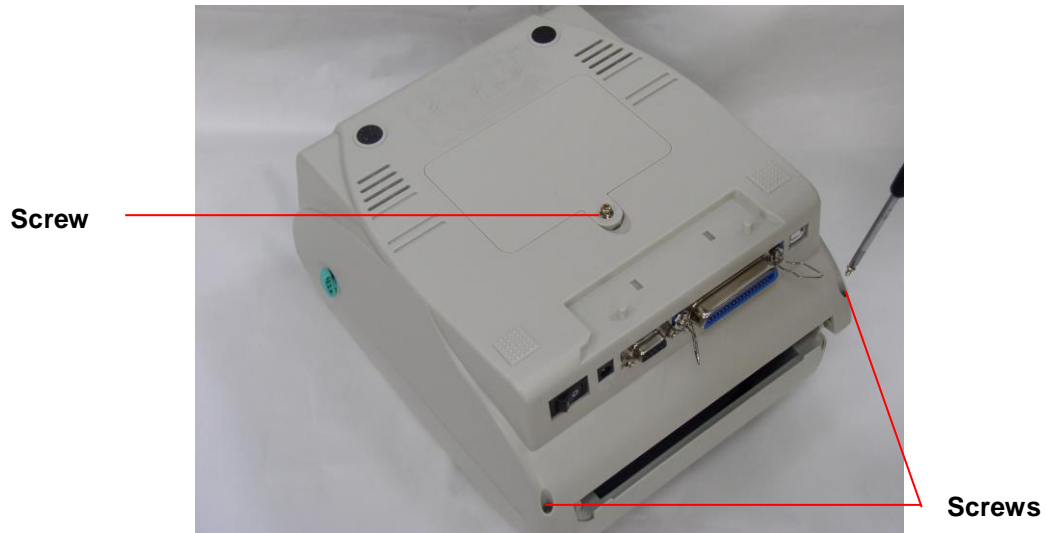

3. Remove 6 screws on **lower inner cover**.

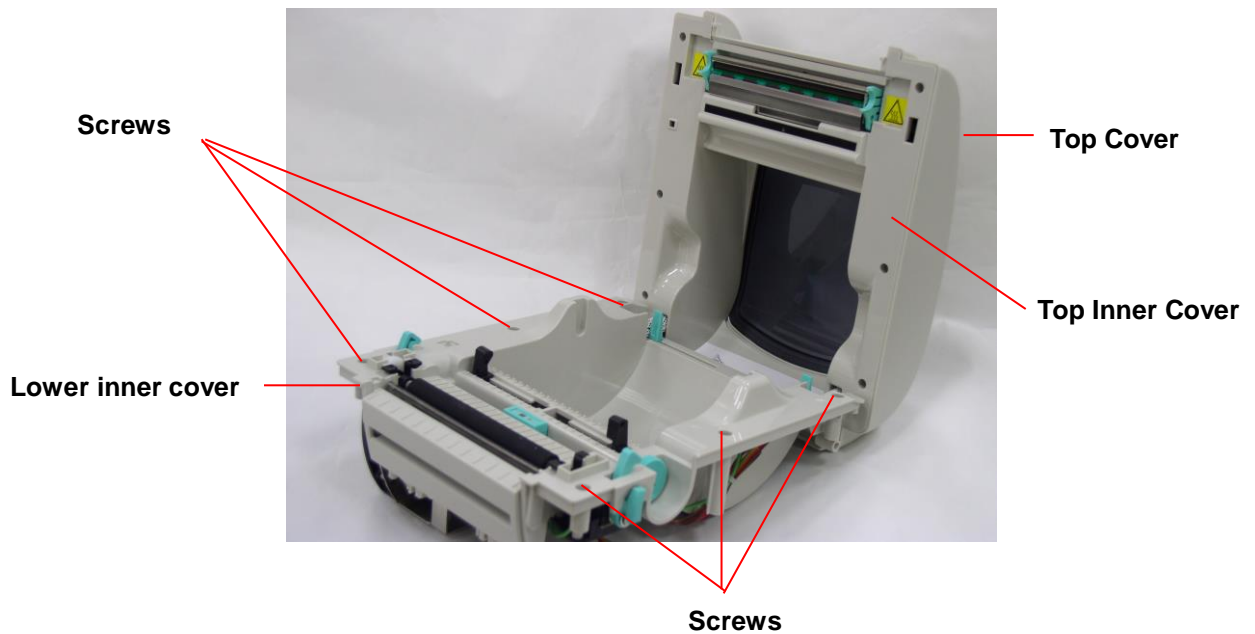

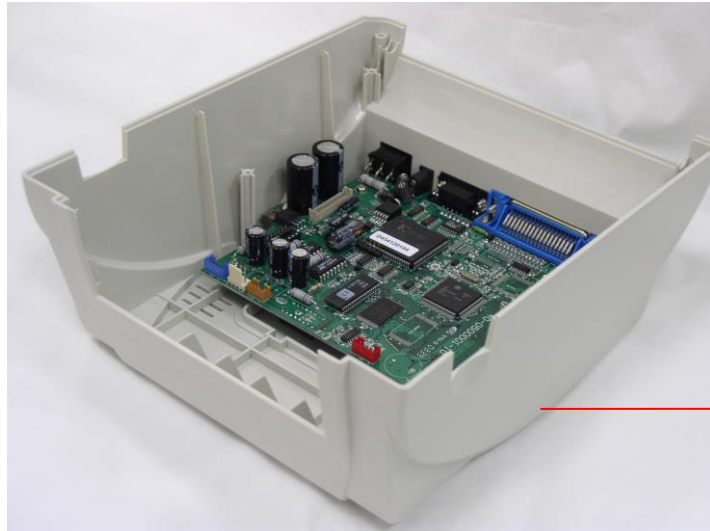

Lower Cover

4. Remove all the harness connected to main board.
5. Remove 4 screws on PCB.

Main Board



Screws

Lower Cover

Screws

6. Replace the PCB or replace a new **lower cover**.
7. Reassemble parts in reverse procedures.

3.3. Replacing Platen Assembly

1. Squeeze two sides of **platen assembly** and take it out.

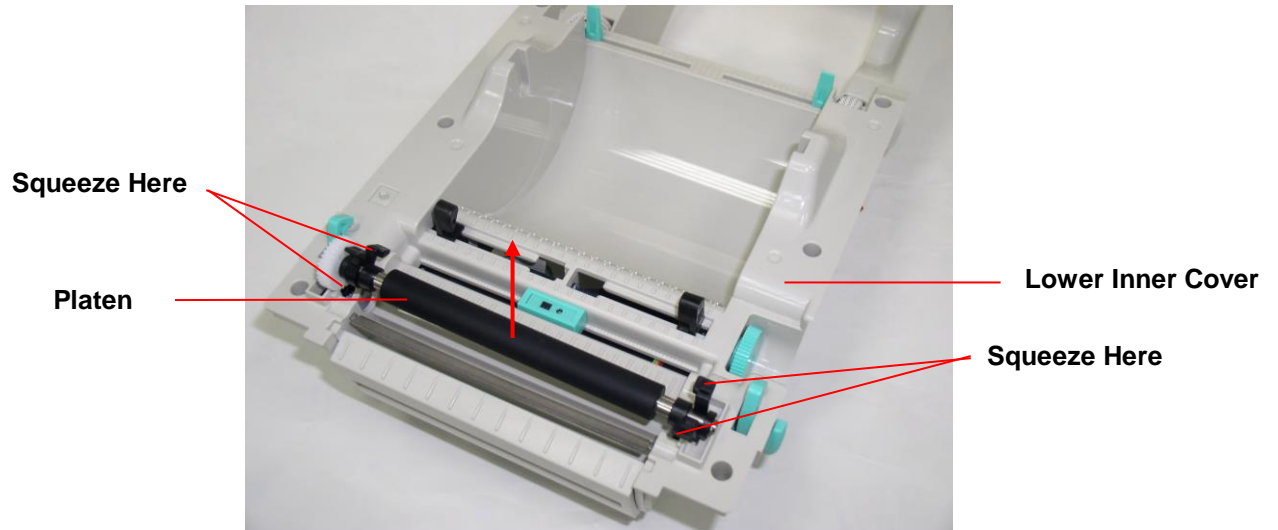

2. Replace a platen.
3. Reassemble parts in reverse procedures.

3.4. Replacing the Stepping Motor Assembly and Stepping

Motor

1. Please refer to 3.2 for disassembling the lower cover.
2. Upside down the lower inner cover.
3. Remove 7 screws of the **stepping motor assembly**.

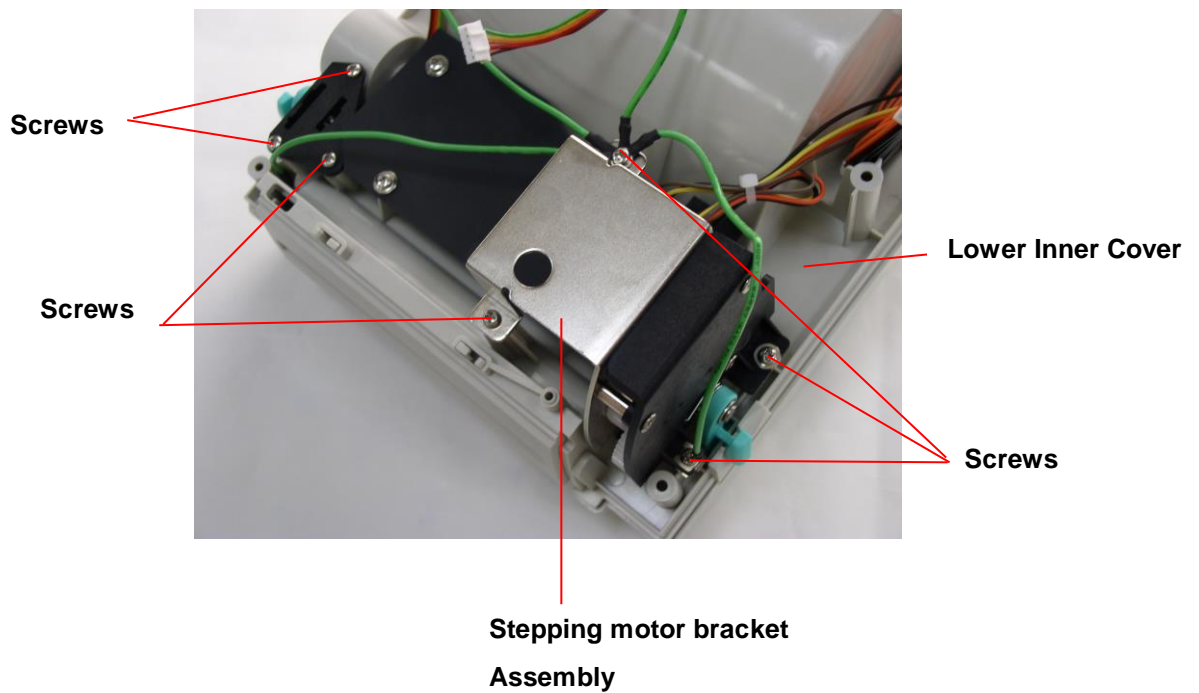

4. Remove the 4 screws of the plastic laminate.
5. Remove the stepping motor assembly.

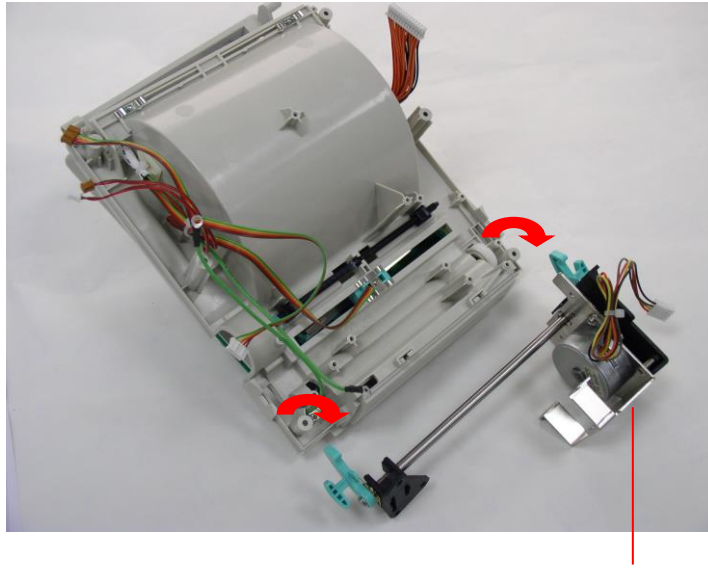

Stepping Motor Assembly

6. Remove 2 screws from the stepping motor assembly; disconnect the stepping motor from stepping motor bracket.

Stepping Motor bracket

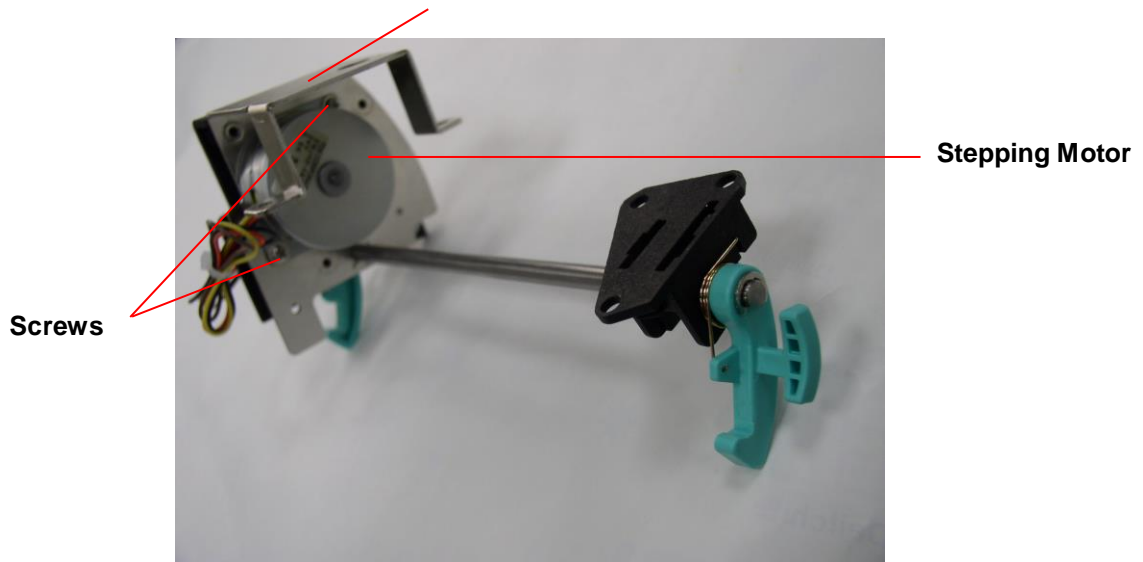

7. Replace the stepping motor.
8. Reassemble parts in reverse procedures.

3.5. Replacing Label Guide Adjustment Knob Assembly

1. Please refer to 3.2 for disassembling the lower cover.
2. Shift the label guide to the **center** by rotating the label guide adjustment knob.
3. Use a flat screwdriver to press the nub to remove the label guide adjustment knob.

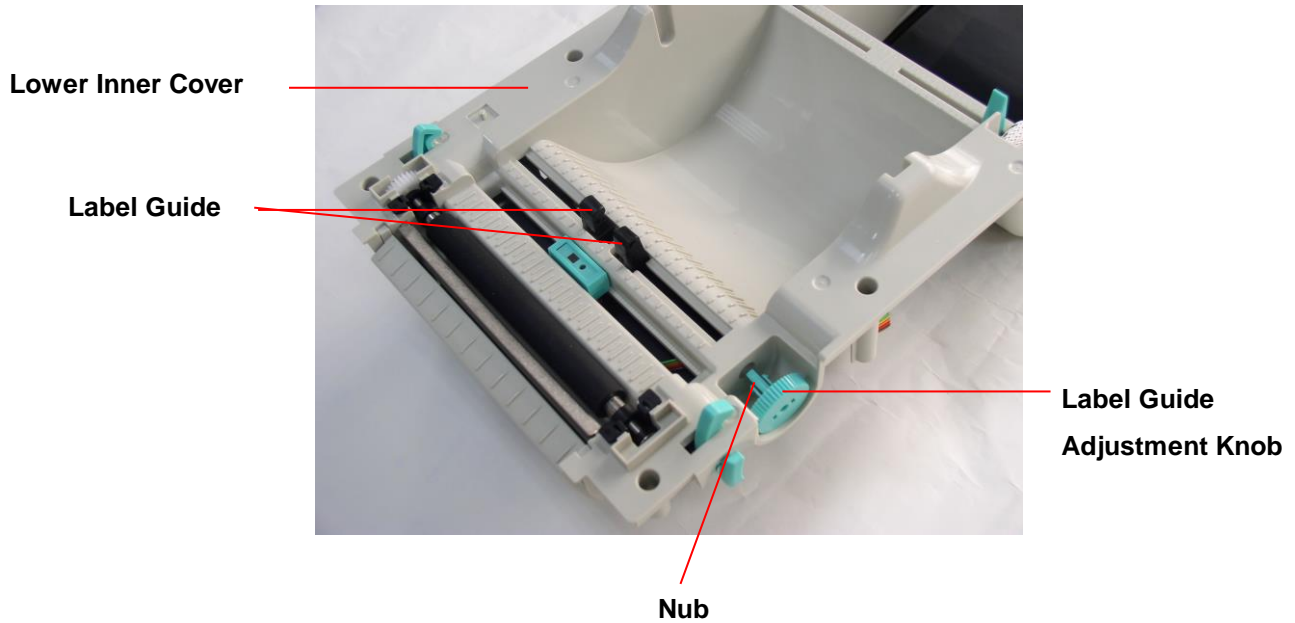

4. Remove 4 screws.

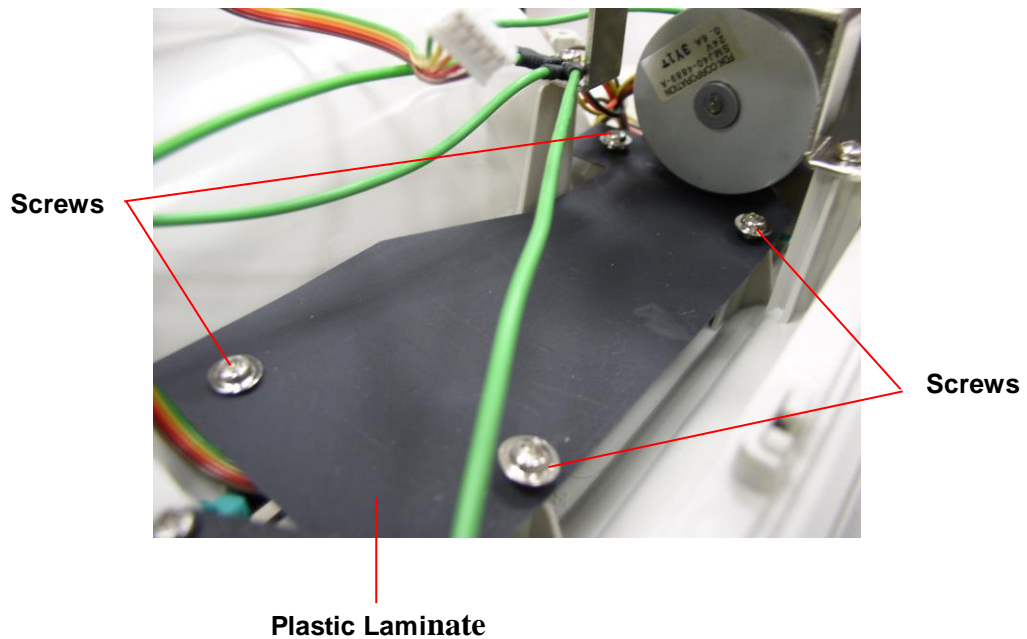

5. Remove the plastic laminate.

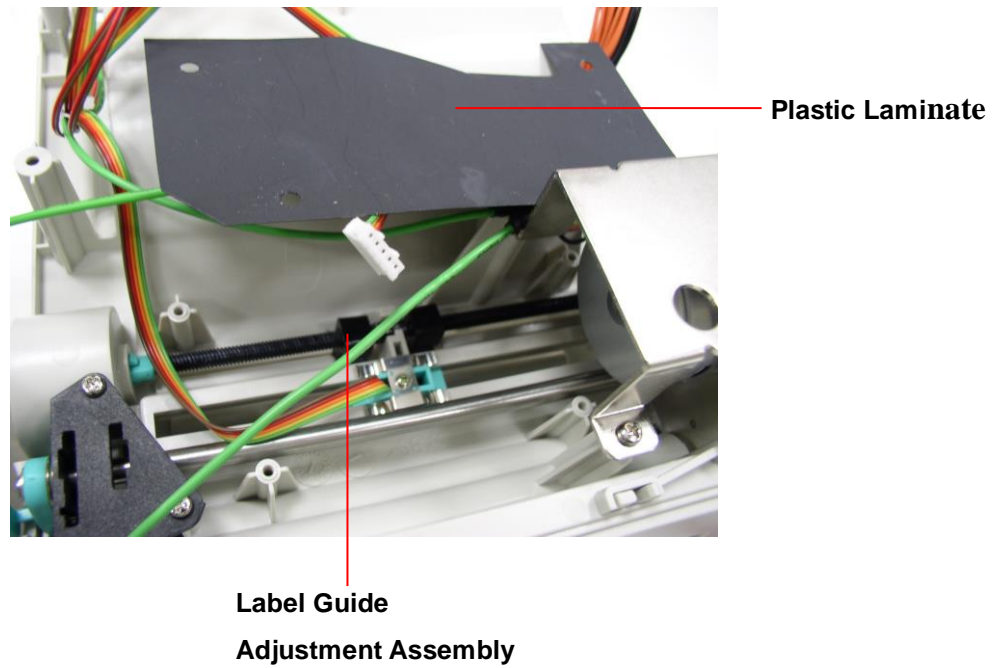

6. Replace the label guide assembly. Make sure the label guides are on the center of the printer.

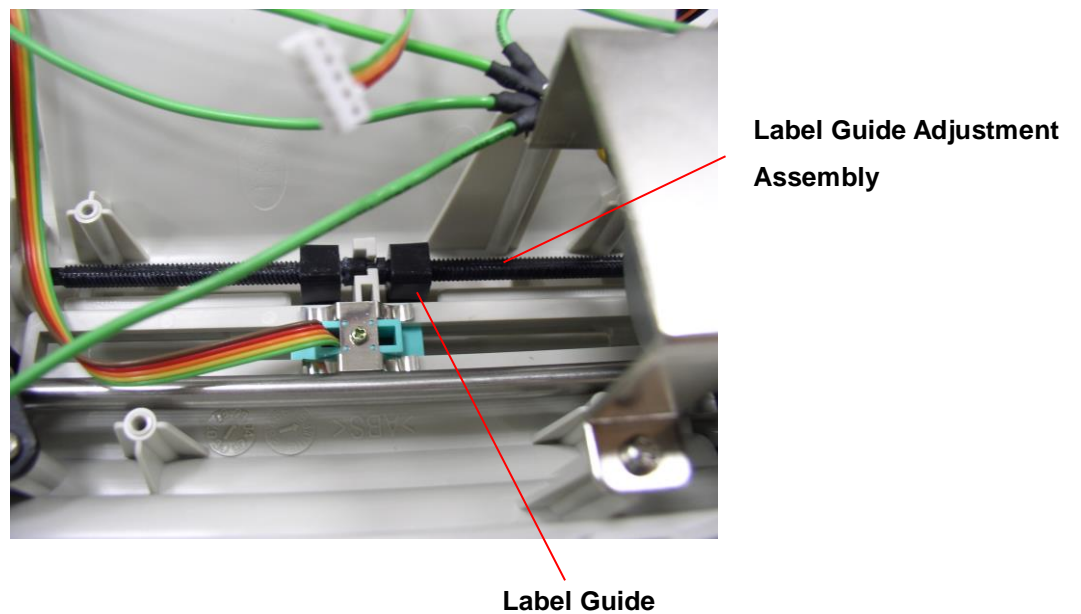

7. Reassemble parts in reverse procedures.

3.6. Replacing Gap/Black Mark Sensor Assembly

1. Please refer to 3.2 for disassembling the lower cover.
2. Turn over the lower inner cover.
3. Remove the plastic laminate. (refer to 3.5)
4. Remove 1 screw from the gap / black mark sensor fixing plate.

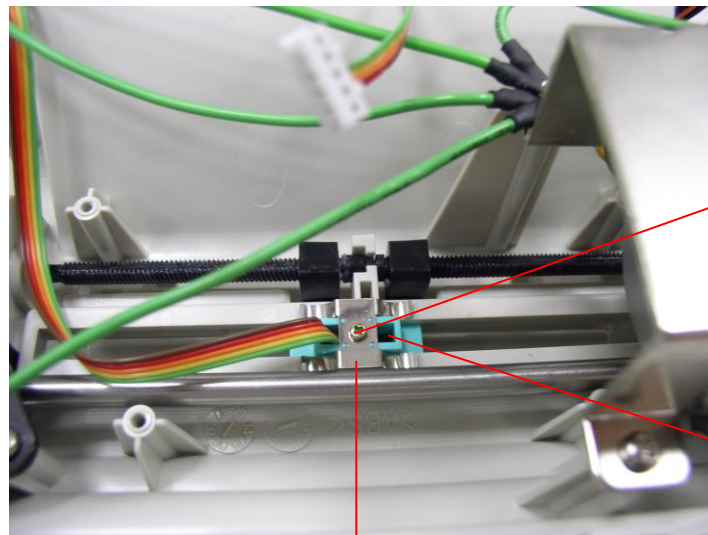

Screw

Gap/Black Mark Sensor

Gap / black mark sensor fixing plate

5. Disconnect the gap/black mark sensor hardness.
6. Upside down the lower inner cover.
7. Remove the gap / black mark sensor.

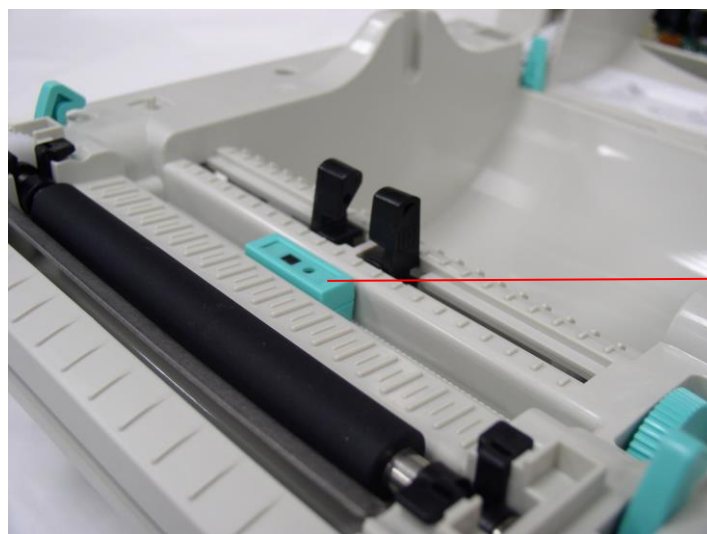

Gap / Black Mark Sensor

8. Reassemble parts in reverse procedures.

3.7. Replacing Print Head Module Assembly

1. Press right slot of the print head **bracket** and use a flat screwdriver to stick left side of the printer head bracket then pick up the print head assembly.

Stick Flat

Screwdriver Here

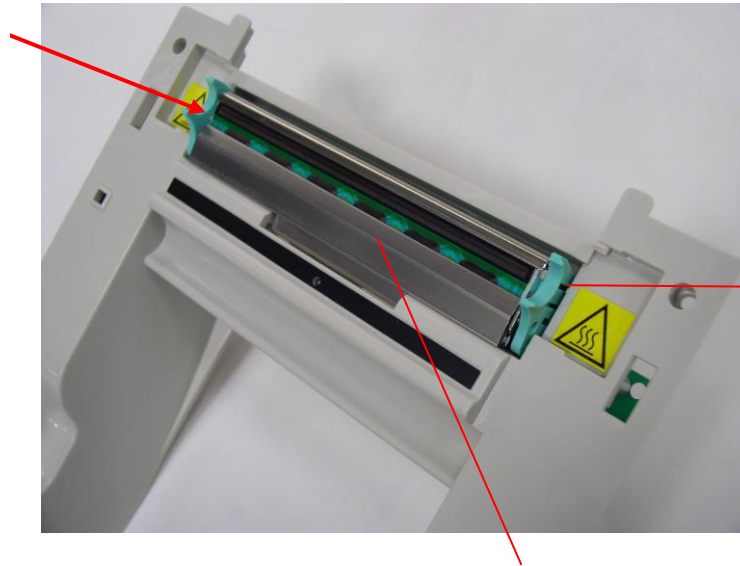

Bracket Concave

Print Head Module Assembly

2. Disconnect print head cables.
3. Reassemble parts in reverse procedures.

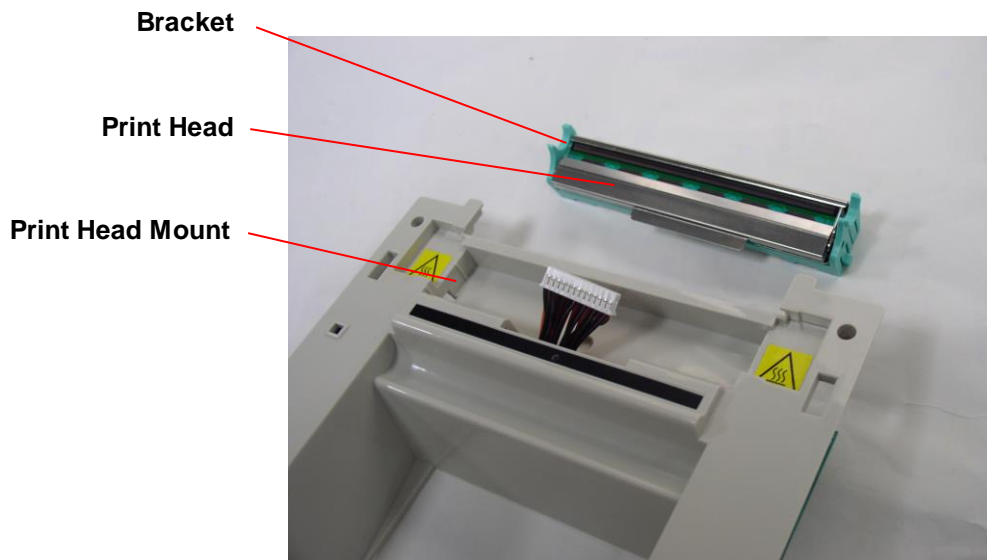

Bracket

Print Head

Print Head Mount

3.8. Replacing Head Open Micro Switch

1. Please refer to 3.1 for disassembling the top cover and top inner cover.
2. Remove JP16 harness from the PCB.
3. Remove 2 screws and remove the **head open micro switch**.

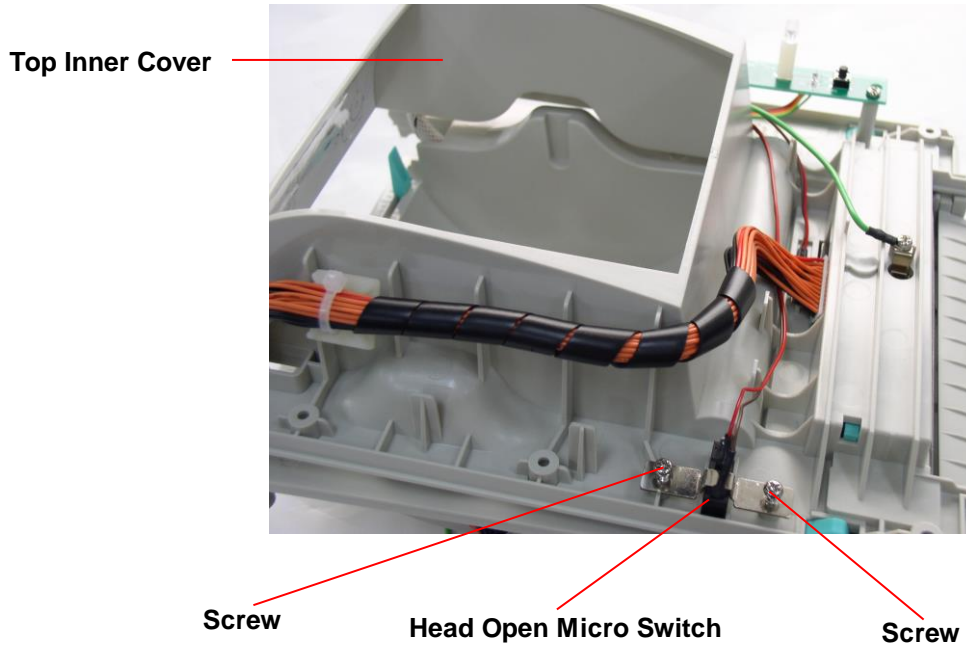

4. Reassemble parts in reverse procedures.

3.9. Replacing Feed Button and Feed Button PCB

1. Please refer to 3.1 for disassembling the top cover and top inner cover.
2. Remove the feed button from top cover.

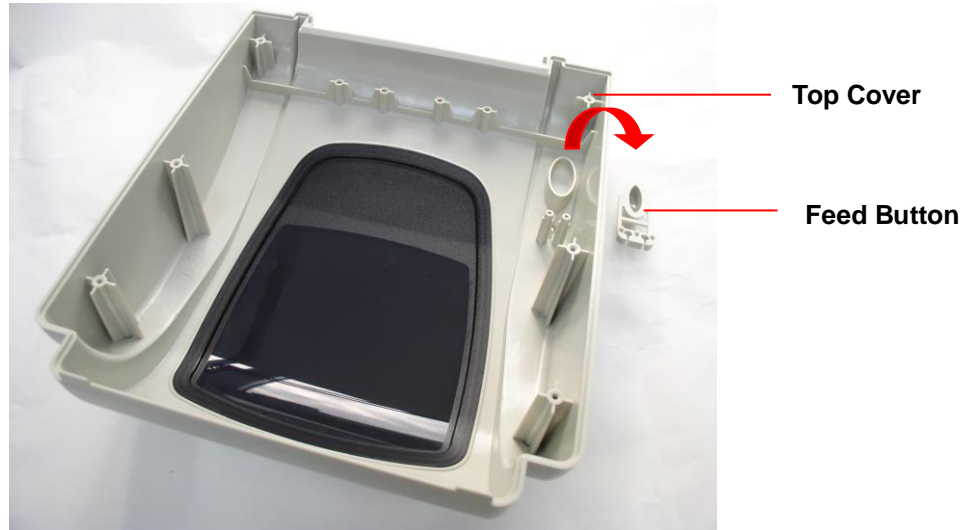

3. Disconnect the JP28 hardness from the PCB
4. Remove 2 screws from the top inner cover and replace the feed button PCB.

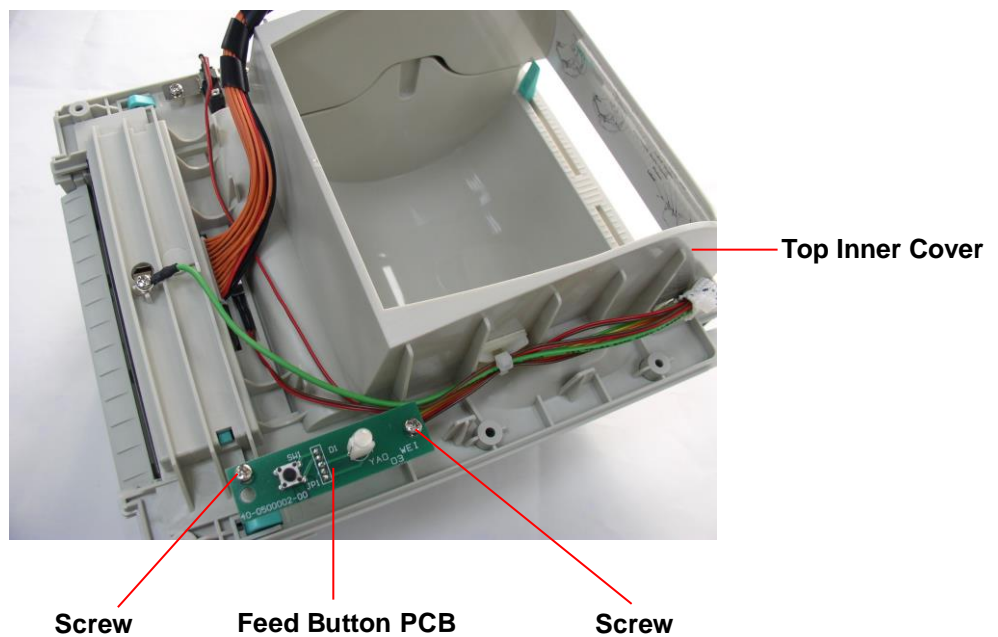

5. Reassemble parts in reverse procedures.

3.10. Install SD Memory Card

1. Upside down the printer.
2. Remove 1 screw and open the memory card cover.



Memory Card Cover

3. Plug in a SD card on main board.



SD Card

4. Revert the memory card cover.
5. Reassemble parts in reverse procedures.

* Recommended SD card specification. (Sandisk, Transcend)

SD card spec	SD card capacity	Approved SD card manufacturer
V1.0, V1.1	128 MB	SanDisk, Transcend
V1.0, V1.1	256 MB	SanDisk, Transcend, Panasonic
V1.0, V1.1	512 MB	SanDisk, Transcend, Panasonic
V1.0, V1.1	1 GB	SanDisk, Transcend, Panasonic
V2.0 SDHC CLASS 4	4 GB	
V2.0 SDHC CLASS 6	4 GB	SanDisk, Transcend, Panasonic
V1.0, V1.1	microSD 128 MB	Transcend, Panasonic
V1.0, V1.1	microSD 256 MB	Transcend, Panasonic

V1.0, V1.1	microSD 512 MB	Panasonic
V1.0, V1.1	microSD 1 GB	Transcend, Panasonic
V2.0 SDHC CLASS 4	microSD 4 GB	Panasonic
V2.0 SDHC CLASS 6	microSD 4 GB	Transcend
V1.0, V1.1	miniSD 128 MB	Transcend, Panasonic
V1.0, V1.1	miniSD 256 MB	Transcend, Panasonic
V1.0, V1.1	miniSD 512 MB	Transcend, Panasonic
V1.0, V1.1	miniSD 1 GB	Transcend, Panasonic
V2.0 SDHC CLASS 4	miniSD 4 GB	Transcend
V2.0 SDHC CLASS 6	miniSD 4 GB	
<ul style="list-style-type: none"> - The DOS FAT file system is supported for the SD card. - Folders/files stored in the SD card should be in the 8.3 filename format - The miniSD/microSD card to SD card slot adapter is required. 		

3.11. Peel-Off Installation (Option) Assembly

1. Open the top cover.
2. Remove two screws in lower cover for hinge holder.

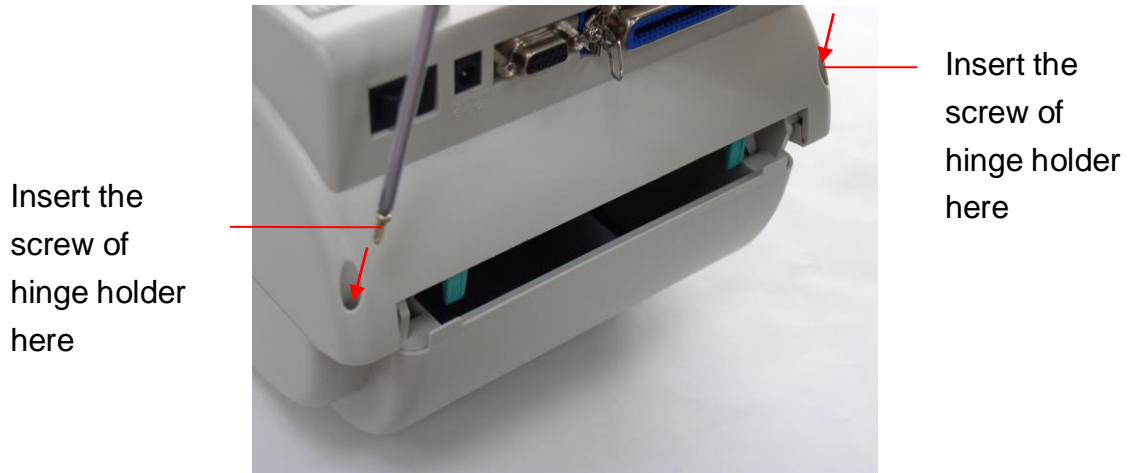

3. Remove 6 screws on the lower inner cover.

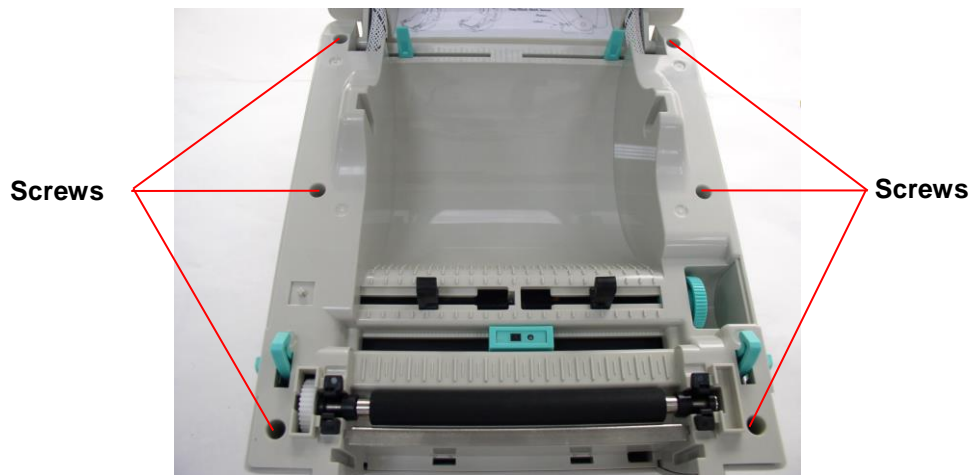

4. Turn the printer upside down.
5. Use a screwdriver to screw off 1 screw on the **bottom**.

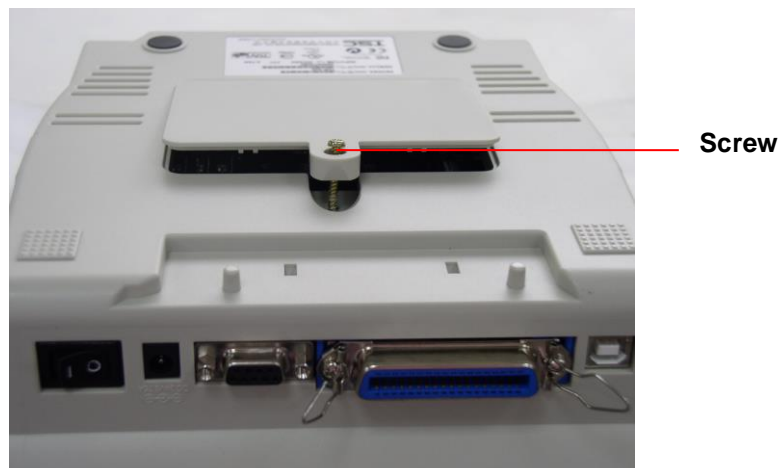

6. Hold the lower cover and lift up the top cover open levers to separate the lower inner cover and the lower cover.

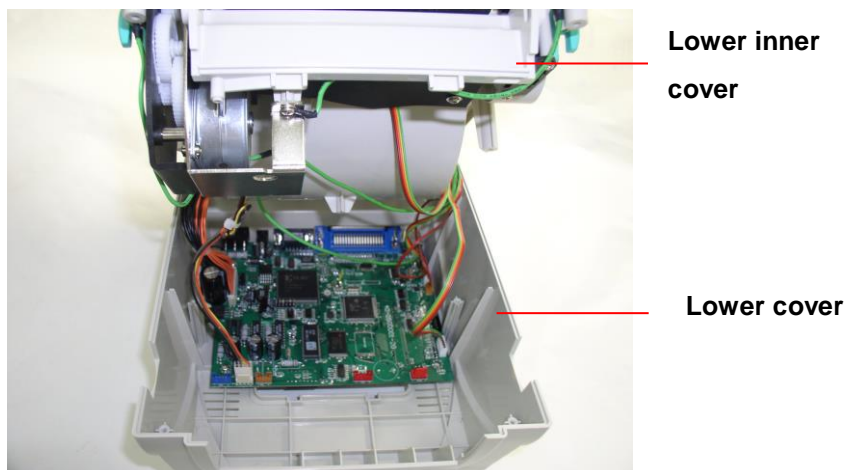

7. Plug the connector (red) of peel-off assembly at the location JP19 on the main board. Pull the wire of the red connector through the slot of lower inner cover front side. Then, put back the lower inner cover.
8. Install the peel-off module to the lower inner cover slot.

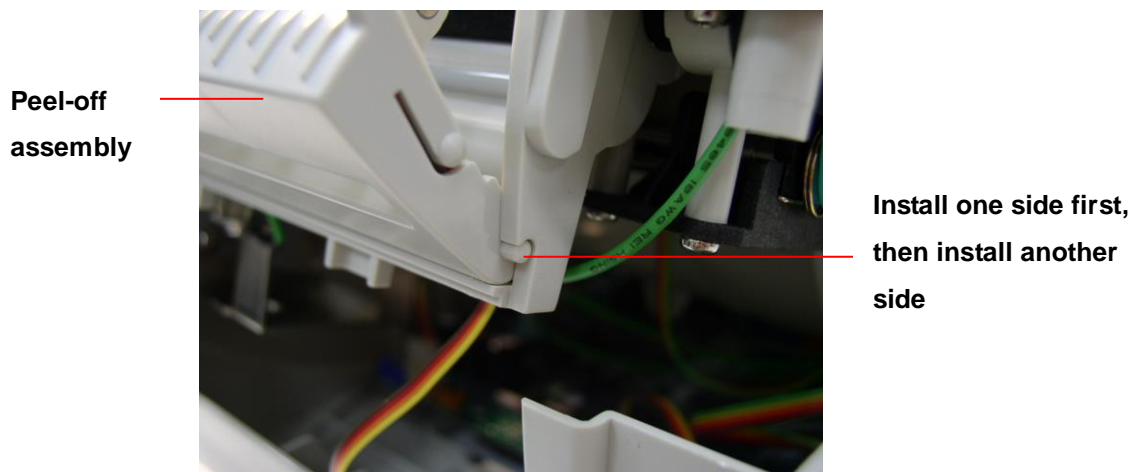

9. Gently push peel-off panel to lock to the lower inner cover.
10. Reassemble parts in reverse procedures.



3.11.1 Loading Label for Peel-off Mode (Option)

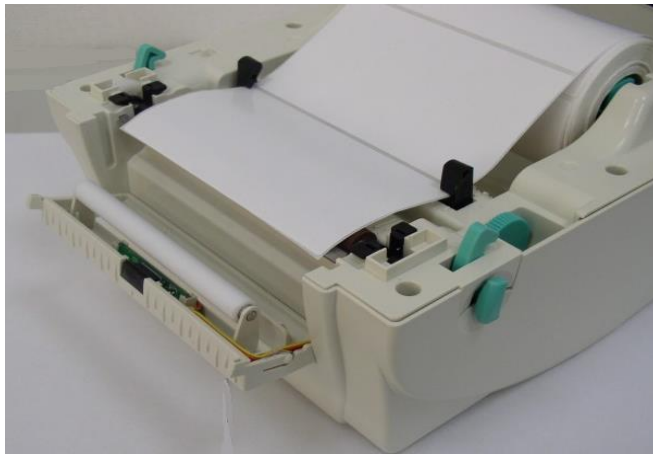

Open the peel-off panel

1. Feed the label, printing side facing up, through the label guide and pass over the platen.
2. Lead the liner paper through the label opening of peel off module, which is beneath the roller.
3. Adjust the center-biased **label guides** in or out by turning adjustment knob so they are slightly touch the edges of the label backing.

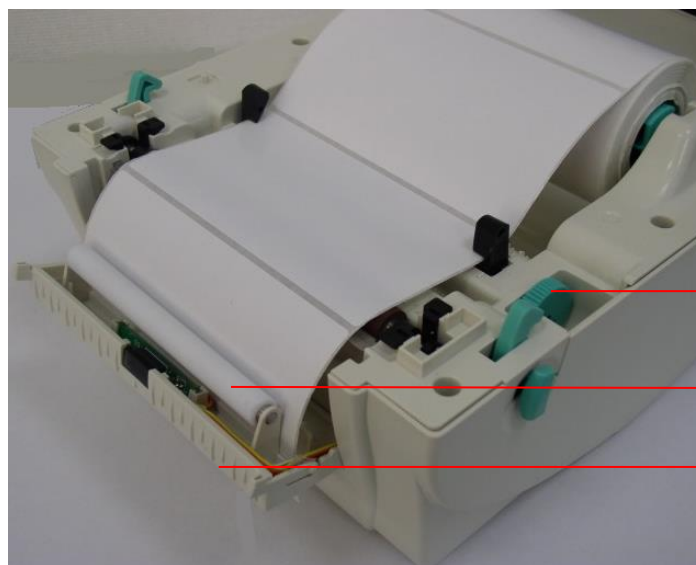

Adjustment Knob

Roller

Peel-off panel

Loading label for peel-off mode

4. Push the peeler back to the printer.
5. Close the top cover.



Label loaded completely in peel-off mode

3.12. Cutter Module Installation (Option)

1. Open the top cover of the printer by pushing the top cover opening levers to the paper outlet direction.
2. Unscrew the 6 screws in the lower inner cover.

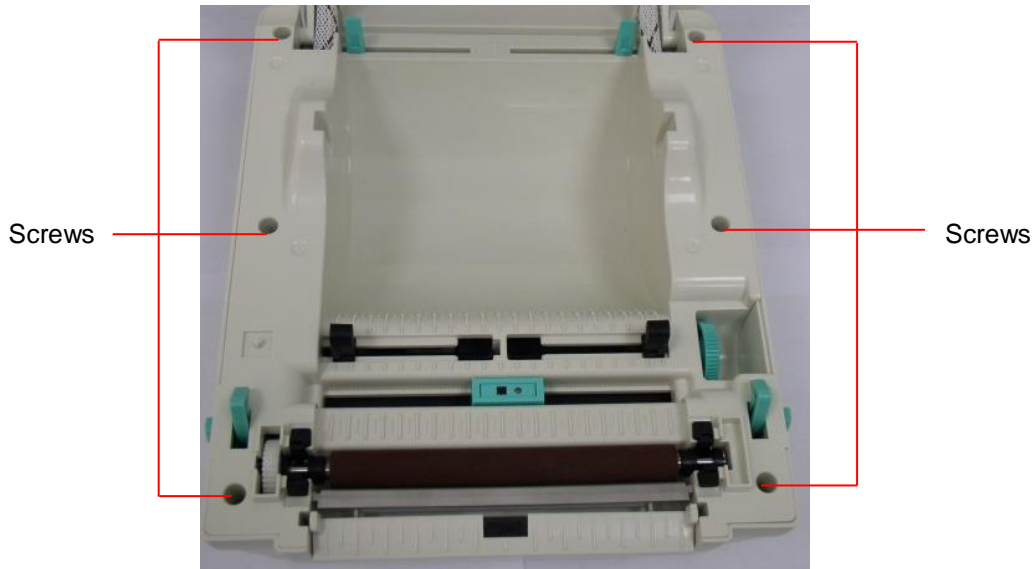

3. Pull up the front panel from the lower cover. Turn the printer upside down.
4. Unscrew the 1 screw of the memory card cover on the bottom.

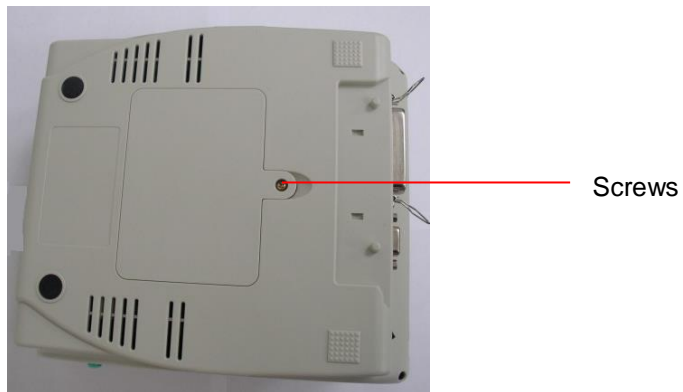

5. Plug in the Cutter Driver IC (or Cutter Driver Board) on the main board locate at U30.

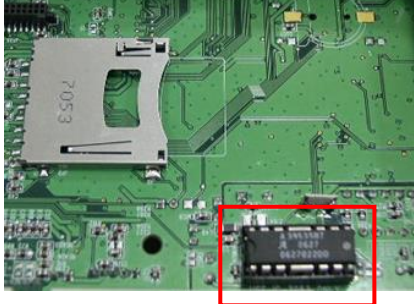
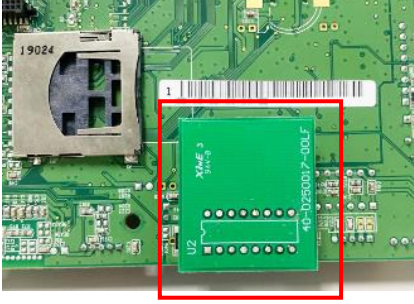
98-0260154-BxLF Main board ass'y / U30	98-0260154-CxLF (or later versions) Main board ass'y / U30
	
Use Cutter Driver IC A4973SB only	Use Cutter Driver board only

Note:

The 98-0260154-CxLF (or later versions) series main board assembly uses the cutter driver board only. It is not compatible with cutter driver IC. Please make sure your main board assembly version before installing cutter module.

6. Hold the lower cover and lift up the top cover open levers to separate the lower inner cover from the lower cover.
7. Put the cutter module cable through the slot of the lower inner cover front side. Connect the cutter module connector to the 4-pin socket on printer PCB.

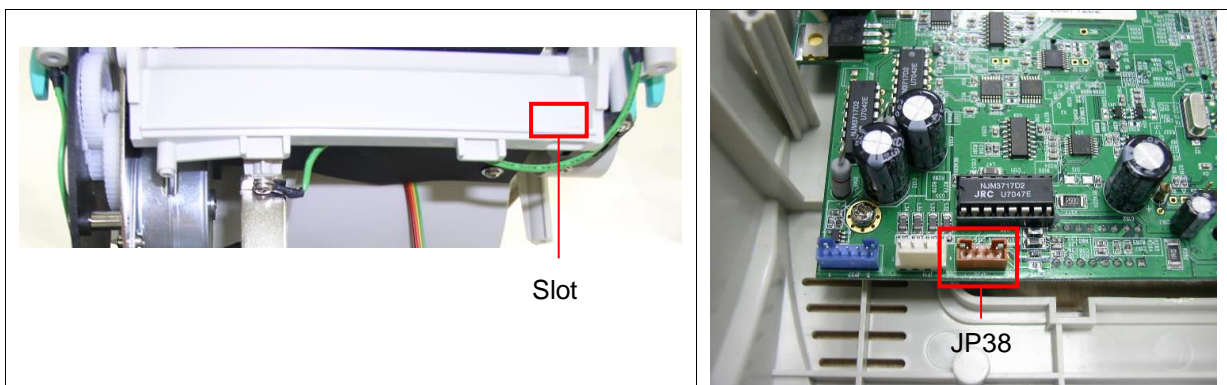

8. Put back the lower inner cover to the lower cover.
9. Gently place the cutter into the niches of the printer.

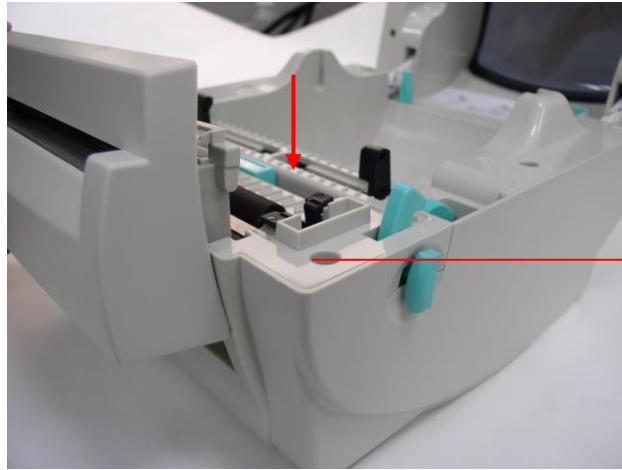

Niche

10. Screw back the 6 screws on the lower inner cover and 1 screw on the back bottom of the printer.

11. Close the top cover.

3.12.1 Loading Label in Cutter Mode

1. Open the top cover of the printer.
2. Insert a paper roller into a paper roll.
3. Place a label roll on the label roll mount. (printing side face up)
4. Feed the paper through the label guide and pass over the platen.
5. Feed the paper through the cutter paper opening.

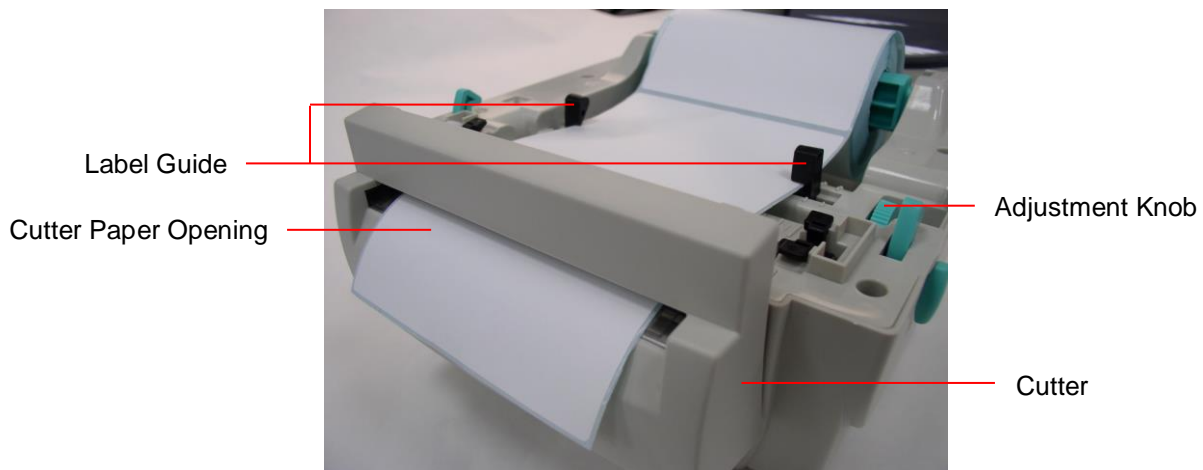

6. Adjust the black center-biased label guides in or out by turning the adjustment knob so they are slightly touch the edges of the label backing.
7. Close the top cover.



Note:

- * Specifications, accessories, parts and programs are subject to change without notice.
- * Except for the linerless cutter, all regular/ heavy duty/ care label cutters DO NOT cut on media with glue. For more details, please refer to the cutter specification in the user's manual.

3.13 Internal Ethernet Interface Installation (Option)

1. Break through the plastic partial tab at the rear side of lower cover to get the RJ45 interface opening.

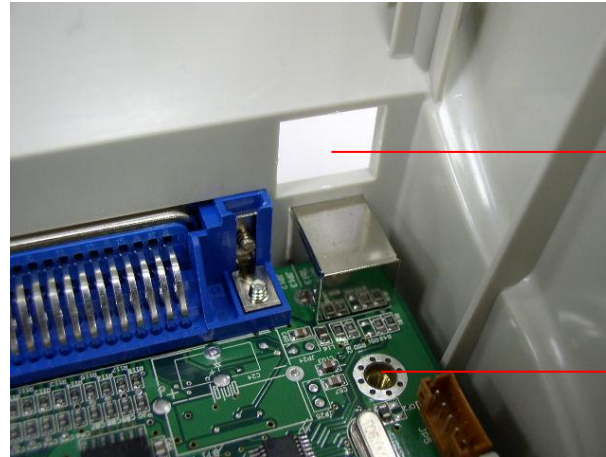

2. Remove the screw from the main board. Fasten the copper pillar and plastic pillar.

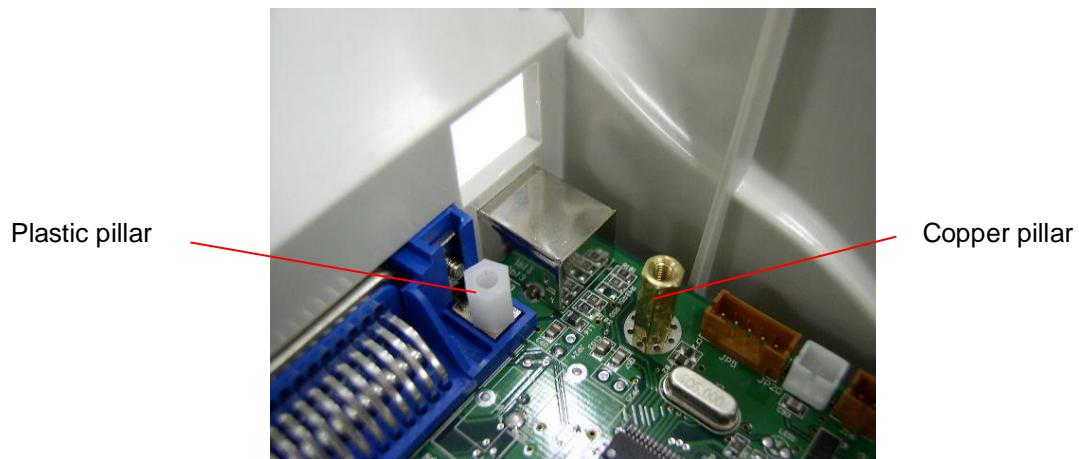

- 3. Fasten the RJ45 connector daughter board upon the plastic and copper pillar. The ground wire from the mechanism must be screwed on the daughter board at copper pillar.

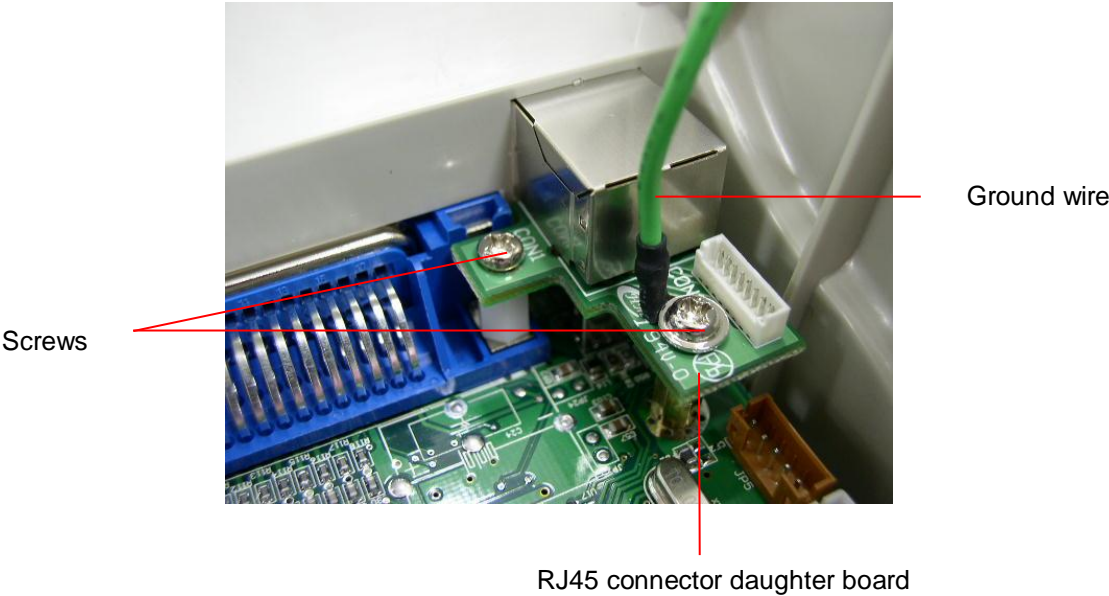

- 4. Plug the 8 pin RJ45 cable to the RJ45 daughter board connector and main board JP43 connector.

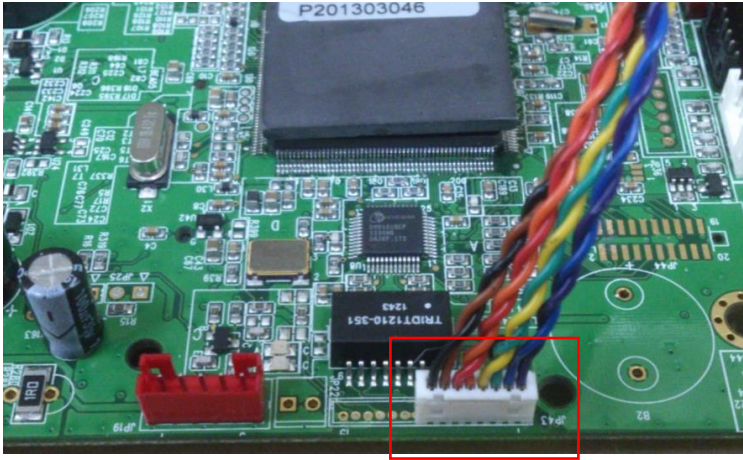

Note: This internal Ethernet interface only supports with the main board that has print server function on board.

4. POWER ON UTILITIES

There are six power-on utilities to set up and test printer hardware. These utilities are activated by pressing FEED button and by turning on the printer power simultaneously.

The utilities are listed as below:

1. Gap/Black Mark sensor calibration
2. Gap/black mark sensor calibration, Self-test and Dump mode
3. Printer initialization
4. Black mark sensor calibration
5. Gap sensor calibration
6. Skip AUTO.BAS

4.1. Gap/Black Mark Sensor Calibration

Gap/black mark sensor sensitivity should be calibrated at the following conditions:

1. A brand new printer
2. Change label stock.
3. Printer initialization.

Please follow the steps below to calibrate the gap/black sensor :

1. Turn off the power switch.
2. Hold on the button then turn on the power switch.
3. Release the button when LED becomes **red** and blinking. (Any red will do during the 5 blinks).

- It will calibrate the gap/black mark sensor sensitivity.
- The LED color will be changed as following order :
Amber → **red (5 blinks)** → amber (5 blinks) → green (5 blinks) → green/amber (5 blinks) → red/amber (5 blinks) → solid green
- It calibrates the sensor and measures the label length.

Note:

Please select gap or black mark sensor by GAP or BLINE command prior to calibrate the sensor.

For more information about GAP and BLINE command, please refer to TSPL2 programming manual.

4.2. Gap/Black Mark Sensor Calibration ; Self-test ; Dump

mode

While calibrate the gap/black mark sensor, printer will measure the label length, print the internal configuration (self-test) and then enter the dump mode.

Please follow the steps as below.

1. Turn off the power switch.
2. Hold on the button then turn on the power switch.
3. Release the button when LED becomes **amber** and blinking. (Any amber will do during the 5 blinks).

- The LED color will be changed as following order.
Amber → red (5 blinks) → **amber (5 blinks)** → green (5 blinks) → green/amber (5 blinks) → red/amber (5 blinks) → solid green
- It calibrates the sensor and measures the label length and prints internal settings then enter the dump mode.

Note:

Please select gap or black mark sensor by Diagnostic Tool or by GAP or BLINE command prior to calibrate the sensor.

For more information about GAP and BLINE command, please refer to TSPL2 programming manual.

Dump mode

Printer will enter dump mode after printing printer configuration. In the dump mode, all characters will be printed in 2 columns as following. The left side characters are received from your system and right side data are the corresponding hexadecimal value of the characters. It allows users or engineers to verify and debug the program.

ASCII Data →	<pre> SPEED 2.0 53 50 45 45 44 20 32 2E 30 0D DENSITY 8 0A 44 45 4E 53 49 54 59 20 38 SET PEEL 0D 0A 53 45 54 20 50 45 45 4C OFF DIRE 20 4F 46 46 0D 0A 44 49 52 45 CTION 0 0 43 54 49 4F 4E 20 30 0D 0A 47 AP 3.00 mm 41 50 20 33 2E 30 30 20 6D 6D .0.00 mm 2C 30 2E 30 30 20 6D 6D 0D 0A REFERENCE 52 45 46 45 52 45 4E 43 45 20 0.0 SET C 30 2C 30 0D 0A 53 45 54 20 43 UTTER OFF 55 54 54 45 52 20 4F 46 46 0D SIZE 100. 0A 53 49 5A 45 20 31 30 30 2E 02 mm,65.0 30 32 20 6D 6D 2C 36 35 2E 30 4 mm CLS 34 20 6D 6D 0D 0A 43 4C 53 0D BARCODE 1 0A 42 41 52 43 4F 44 45 20 31 44.149,"39 34 34 2C 31 34 39 2C 22 33 39 ",120,1,0. 22 2C 31 32 30 2C 31 2C 30 2C 2.6,"57114 32 2C 36 2C 22 35 37 31 31 34 38T" PRIN 33 38 54 22 0D 0A 50 52 49 4E T 1,1 SPE 54 20 31 2C 31 0D 0A 53 50 45 ED 2.0 DE 45 44 20 32 2E 30 0D 0A 44 45 NSITY 8 S 4E 53 49 54 59 20 38 0D 0A 53 ET PEEL OF 45 54 20 50 45 45 4C 20 4F 46 F DIRECTI 46 0D 0A 44 49 52 45 43 54 49 ON 0 GAP 4F 4E 20 30 0D 0A 47 41 50 20 3.00 mm,0. 33 2E 30 30 20 6D 6D 2C 30 2E 00 mm REF 30 30 20 6D 6D 0D 0A 52 45 46 ERENCE 0,0 45 52 45 4E 43 45 20 30 2C 30 SET CUTT 0D 0A 53 45 54 20 43 55 54 54 ER OFF SI 45 52 20 4F 46 46 0D 0A 53 49 ZE 100.02 5A 45 20 31 30 30 2E 30 32 20 mm,65.04 m 6D 6D 2C 36 35 2E 30 34 20 6D m CLS BA 6D 0D 0A 43 4C 53 0D 0A 42 41 RCODE 144. 52 43 4F 44 45 20 31 34 34 2C 149,"39",1 31 34 39 2C 22 33 39 22 2C 31 20,1,0,2,6 32 30 2C 31 2C 30 2C 32 2C 36 ,"5711438T 2C 22 35 37 31 31 34 33 38 54 " PRINT 1 22 0D 0A 50 52 49 4E 54 20 31 ,1 2C 31 0D 0A </pre>	→ Hex decimal data related to left column of ASCII data
--------------	---	---

Dump mode printout

Note :

Turn off and on the power switch to reset the printer for normal printing.

4.3 Printer Initialization

Printer initialization is used to clear DRAM and restore printer settings to defaults. The only one exception is ribbon sensitivity, which will not be restored to default.

Printer initialization is activated by the following procedures.

1. Turn off the power switch.
2. Hold on the button then turn on the power switch.
3. Release the button when LED turns **green** after 5 amber blinks. (Any green will do during the 5 blinks).
 - The LED color will be changed as following:
Amber → red (5 blinks) → amber (5 blinks) → **green (5 blinks)** → green/amber (5 blinks) → red/amber (5 blinks) → solid green

Printer configuration will be restored to defaults as below after initialization.

Parameter	Default setting
Speed	203 dpi: 127 mm/sec (5 ips) 300 dpi: 76 mm/sec (3 ips)
Density	8
Label Width	4" (101.6 mm)
Label Height	4" (101.6 mm)
Media Sensor Type	Gap sensor
Gap Setting	0.12" (3.0 mm)
Print Direction	0
Reference Point	0,0 (upper left corner)
Offset	0
Tear Mode	On
Peel off Mode	Off
Cutter Mode	Off
Serial Port Settings	9600 bps, none parity, 8 data bits, 1 stop bit
Code Page	850
Country Code	001
Clear Flash Memory	No
IP Address	DHCP

Note :

Always do gap/black mark sensor calibration after printer initialization.

4.4 Black Mark Sensor Calibration

Set black mark sensor as media sensor and calibrate the black mark sensor.

Please follow the steps as below.

1. Turn off the power switch.
2. Hold on the button then turn on the power switch.
3. Release the button when LED turns **green/amber** after 5 green blinks. (Any green/amber will do during the 5 blinks).
 - The LED color will be changed as following:
Amber → red (5 blinks) → amber (5 blinks) → green (5 blinks) → **green/amber (5 blinks)** → red/amber (5 blinks) → solid green

4.5 Gap Sensor Calibration

Set gap sensor as media sensor and calibrate the gap sensor.

Please follow the steps as below.

1. Turn off the power switch.
2. Hold on the button then turn on the power switch.
3. Release the button when LED turns **red/amber** after 5 green/amber blinks. (Any red/amber will do during the 5 blinks).
 - The LED color will be changed as following:
Amber → red (5 blinks) → amber (5 blinks) → green (5 blinks) → green/amber (5 blinks) → **red/amber (5 blinks)** → solid green

4.6 Skip AUTO.BAS

TSPL2 programming language allows user to download an auto execution file to flash memory. Printer will run the AUTO.BAS program immediately when turning on printer power. The AUTO.BAS program can be interrupted without running the program by the power-on utility.

Please follow the steps as below.

1. Turn off printer power.
2. Press the FEED button and then turn on power.
3. Release the FEED button when LED becomes **solid green**.
 - The LED color will be changed as following:
Amber → red (5 blinks) → amber (5 blinks) → green (5 blinks) → green/amber (5 blinks) → red/amber (5 blinks) → **solid green**
4. Printer will be interrupted to run the AUTO.BAS program.

5. GAP AND BLACK MARK SENSOR SELECTION

Both gap sensor and black mark sensor are available in TDP-245 Plus series. Gap sensor is set as default, so there is no extra setting for gap sensor.

Gap Sensor

- Default setting. No extra action necessary.
- If you would like to switch back to gap sensor, please initialize the printer.

Black Mark Sensor

- Go to MS-DOS prompt mode and enter following command to switch sensor to black mark sensor.
- **C:\>COPY CON LPT1 <ENTER>**
BLINE *width, offset* <CTRL><Z> *ex: BLINE 3 mm, 0*
C:\>

Or start the labeling software, set sensor to black mark sensor then print one label. The sensor will be switched to black mark sensor.

Please calibrate the sensor after sensor selection.

Note:

1. <ENTER> means PC keyboard “Enter” key.
2. <CTRL><Z> means to hold “CTRL” key then press “Z” key.

6. DIAGNOSTIC TOOL

The Diagnostic Utility is a toolbox that allows users to explore the printer's settings and status; change printer settings; download graphics, fonts, and firmware; create printer bitmap fonts; and to send additional commands to the printer. Using this convenient tool, you can explore the printer status and settings and troubleshoot the printer.

Note: This utility works with printer firmware V6.00 and later versions.

6.1 Start the Diagnostic Tool

1. Double click on the Diagnostic tool icon  **DiagTool.exe** to start the software.
2. There are four features (Printer Configuration, File Manager, Bitmap Font Manager, Command Tool) included in the Diagnostic utility.

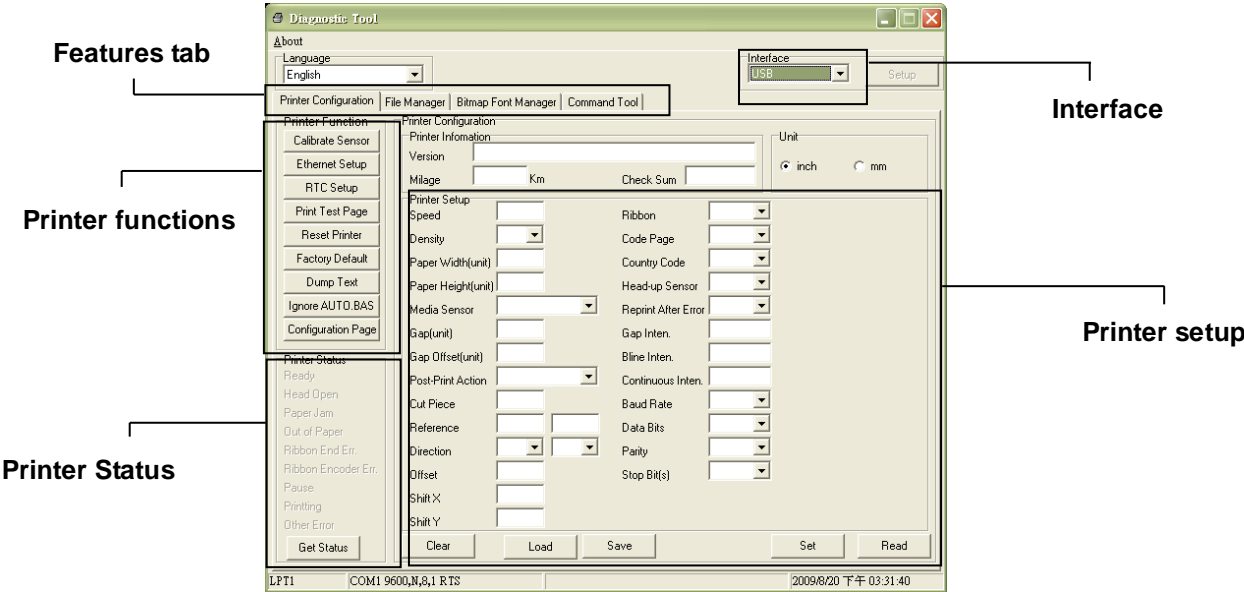

6.2 Printer Function (Calibrate sensor, Ethernet setup, RTC setup.....)

1. Select the PC interface connected with bar code printer.
2. Click the “Function” button to setting.
3. The detail functions in the Printer Function Group are listed as below.

Printer Function	Function	Description
Calibrate Sensor	Calibrate Sensor	Calibrate the sensor specified in the Printer Setup group media sensor field
Ethernet Setup	Ethernet Setup	Setup the IP address, subnet mask, gateway for the on board Ethernet
RTC Setup	RTC Time	Synchronize printer Real Time Clock with PC
Print Test Page	Print Test Page	Print a test page
Reset Printer	Reset Printer	Reboot printer
Factory Default	Factory Default	Initialize the printer and restore the settings to factory default.
Dump Text	Dump Text	To activate the printer dump mode.
Ignore AUTO.BAS	Ignore AUTO.BAS	Ignore the downloaded AUTO.BAS program
Configuration Page	Configuration Page	Print printer configuration

Note:
For more information about Diagnostic Tool, please refer to the diagnostic utility quick start guide in the CD disk \ Utilities directory.

7. TROUBLESHOOTING

This section lists the common problems that you may encounter when operating the printer.

1. **LED does not light on.**

- Turn the power switch on.
- Measure if there is 24V DC from the power supply output plug. Change the power adaptor if 24V DC is not been measured.
- Check if U32 (5VDC) and U22 (3.3VDC) of the main board are broken. Change main board if one of them is broken; Or measure if JP 22 (5VDC) and the terminal of R316 close to C139 side (3.3VDC) are correct voltage. Change main board if their voltages are been measured incorrectly.

2. **The printer is paused.**

- Press the FEED button to resume printing.

3. **The LED is on red and blinking.**

If the LED is red and blinking, which means that the label runs out or paper sensor error. We also can use diagnostic tool to get the printer status through COM port or USB port.

Label runs out (Out of paper):

- Load a roll of label and follow the instructions as following and then press the FEED button to resume printing.
 1. Insert a paper spindle into a paper roll
 2. Open the printer's top cover by releasing the top cover open lever located on both sides of printer and lifting the top cover..
 3. Place a new paper roll into paper roll mount.
 4. Feed the paper, printing side face up, through the label guide and pass over the platen.
 5. Adjust the label guide to fit the paper width
 6. Close the printer top cover slowly and make sure the cover locks latch securely.

Paper sensor error

Please check the following items:

- A. Is label installed correctly? Please refer to previous **4. The LED is on red blinking** – *Label runs out* to load a roll of label and then press the FEED

button to resume printing.

- B. Is there any label stuck on the label sensor? Is there any pre-printed logo on the label? Please refer to **5.3 Printer Initialization** to reset the system.

If the pre-printed logo or text influences the auto gap calibration function, please calibrate the gap sensor with proper sensitivity setting by try and error method.

Example:

C:\>COPY CON LPT1 <Enter>

SET GAP 1 <Ctrl> <Z>

Main board, gap sensor or black sensor failure.

- If you confirm the main board is good, Please change the gap sensor receiver first, because the receiver sensor failure rate is higher than the transmitter sensor.

4. **The printer setting runs error.**

Printer setting runs error:

Refer to **5.3 Initialization** to reset the system.

5. **Continuous feeding labels**

- The printer setting may go wrong. Please do “Printer Initialization” and “Gap and Black Mark Sensor Calibration”. (Refer to 5.2 and 5.3).

6. **No print on the label**

- Is the thermal head connector connected?
- Is the thermal head broken? Check it by printer self-test printout.
- Is main PCB U14, U15, Q1 or Q2 broken?

7. **Printer does not print.**

Printed by enclosed BarTender

- This may be driver conflict problem. Please remove all the drivers in the printer folder and then re-install the driver for your printer.

Printed by printer command (other error).

- This problem is caused by incorrect syntax commands. This printer will ignore incorrect syntax commands. Please set the printer to the dump mode and make sure the printed command is identical to the commands sent from the application software.

- The printer serial port setting is not correspondent to the PC's setting. Please do the configuration by the following commands.

C:\>COPY CON LPT1 <Enter>

```
SET COM1 96,N,8,1 <Enter>
<Ctrl>Z<Enter>
C:\>
```

8. **Poor print quality**

- The dust or glue from label may stick onto the print head. Wipe the thermal print head by the soft cloth soaked with Ethanol.
- Adjust the print density setting.
- If this problem happens after changing a new print head module, adjust the print head's heater line position by re-assembling print head module.

9. **Stepping motor does not feed label**

- Is stepping motor function abnormal?.
- Check if U18, and U19 (3717 driver IC) of main board are broken?

10. **LED keeps at solid amber**

- Is switching power broken?
- Is main board broken? Please replace a new main board.
- Try to update the firmware on line. Press the FEED and power on the printer at same time. Press the FEED again while the first green LED is on. Finally, transmit the firmware program to the printer from PC.

11. **Cutter functions abnormally.**

Cutter is not activated (other error)

At first, check if cutter is broken or the main PCB is damaged. If it still has problem after changing a new cutter, perhaps the U30 (driver IC) ,U28 IC or U34 on the main board was broken. Otherwise, check if the pin 28 of U2 (CPU) is good.

12. **Black mark can't be detected properly (out of paper or paper jam)**

- Please check if the position of the black mark on label is correspondent with black mark sensor.
Is the width of black mark on label too thin to be detected? The recommended black mark width is wider than 12 mm.

8. MAINTENANCE

This session presents the clean tools and methods to maintain your printer.

1. Please use one of following material to clean the printer.

- Cotton swab (Head cleaner pen)
- Lint-free cloth
- Vacuum / Blower brush
- 100% ethanol

2. The cleaning process is described as following

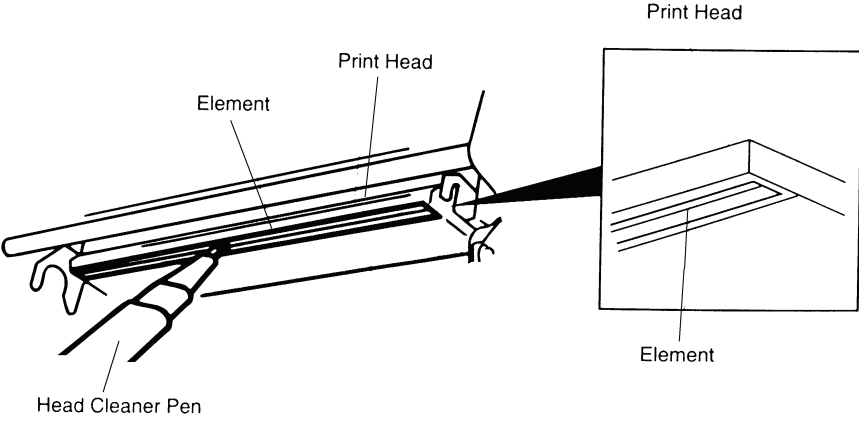
Printer Part	Method	Interval
<p>Print Head</p>	<p>1. Always turn off the printer before cleaning the print head.</p> <p>2. Allow the print head to cool for a minimum of one minute.</p> <p>3. Use a cotton swab (Head cleaner pen) and 100% ethanol to clean the print head surface.</p>	<p>Clean the print head when changing a new label roll</p>
 <p>The diagram illustrates the cleaning of the print head. It shows a hand holding a 'Head Cleaner Pen' and applying it to the 'Print Head' surface. The 'Print Head' is shown in a perspective view, with a callout box providing a magnified view of the 'Element' (the nozzle area). Labels include 'Print Head', 'Element', and 'Head Cleaner Pen'.</p>		
<p>Platen Roller</p>	<p>1. Turn the power off.</p> <p>2. Rotate the platen roller and wipe it thoroughly with 100% ethanol and a cotton swab, or lint-free cloth.</p>	<p>Clean the platen roller when changing a new label roll</p>
<p>Tear Bar/Peel Bar</p>	<p>Use the lint-free cloth with 100% ethanol to wipe it.</p>	<p>As needed</p>
<p>Sensor</p>	<p>Compressed air or vacuum</p>	<p>Monthly</p>
<p>Exterior</p>	<p>Wipe it with water-dampened cloth</p>	<p>As needed</p>

Interior	Brush or vacuum	As needed
-----------------	-----------------	-----------

Note:

- Do not touch printer head by hand. If you touch it carelessly, please use ethanol to clean it.
- Please use 100% Ethanol. DO NOT use medical alcohol, which may damage the printer head.
- Regularly clean the print head and supply sensors once change a new ribbon to keep printer performance and extend printer life.

UPDATE HISTORY

Date	Content	Editor
2008/4/17	Add the part no. for Switzerland type power cord	Camille
2008/4/22	Modify e the description for 98-0260184-00LF (Main board ass'y with internal print server kit)	Camille
2008/6/17	Modify the TPH plastic bracket part no.	Camille
2008/7/4	Remove the parts list section	Camille
2008/12/12	Add connector JP6 description	Camille
2009/3/16	Modify section 3.10 (Recommended SD card specification)	Camille
2009/10/6	Modify section 2.1	Camille
2011/1/13	Add TDP-247/345 models	Camille
2011/1/17	Modify section 2.1, 3.2, 3.13, 4.3, 6.1 and 6.2	Camille
2011/1/25	Modify TSC address	Camille
2011/4/7	Modify section 2.2	Camille
2014/7/31	Modify section 3.13	Camille
2019/8/6	Modify section 3.12 and 3.12.1	Kate



TSC Auto ID Technology Co., Ltd.

Corporate Headquarters

9F., No.95, Minquan Rd., Xindian Dist.,
New Taipei City 23141, Taiwan (R.O.C.)

TEL: +886-2-2218-6789

FAX: +886-2-2218-5678

Web site: www.tscprinters.com

E-mail: printer_sales@tscprinters.com
tech_support@tscprinters.com

Li Ze Plant

No.35, Sec. 2, Ligong 1st Rd., Wujie Township,
Yilan County 26841, Taiwan (R.O.C.)

TEL: +886-3-990-6677

FAX: +886-3-990-5577