

Desktop Barcode Printer

# DH220 Series

*Direct Thermal*

## Series Models

DH220/ DH320

DH220T/ DH320T

DH220THC/ DH320THC



Service Manual

# Copyright Information

© 2023 TSC Auto ID Technology Co., Ltd.

The copyright in this manual, the software and firmware in the printer described are owned by TSC Auto ID Technology Co., Ltd. All rights reserved.

CG Triumvirate is a trademark of Agfa Corporation. CG Triumvirate Bold Condensed font is under license from the Monotype Corporation. Windows is a registered trademark of Microsoft Corporation.

All other trademarks are the property of their respective owners. Information in this document is subject to change without notice and does not represent a commitment on the part of TSC Auto ID Technology Co. No part of this manual may be reproduced or transmitted in any form or by any means, for any purpose other than the purchaser's personal use, without the expressed written permission of TSC Auto ID Technology Co.



# Contents

<b>1</b>	<b>Introduction .....</b>	<b>4</b>
1.1	Printer Features.....	5
<b>2</b>	<b>Electronics .....</b>	<b>8</b>
2.1	Summary of the Board Connectors .....	8
2.2	Interface Pin Configuration .....	20
<b>3</b>	<b>Replacing Parts .....</b>	<b>22</b>
3.1	Before You Begin.....	22
3.2	Replacing the Platen Roller Assembly.....	23
3.3	Replacing the Printhead & Upper Black Mark Sensor .....	25
3.4	Replacing the Top Cover .....	27
3.5	Replacing the Control Panel Assembly .....	28
3.6	Replacing the Lower Cover .....	31
3.7	Replacing the RTC Module .....	33
3.8	Replacing the Main Board .....	34
3.9	Replacing the SD Card Board .....	35
3.10	Replacing the Stepping Motor .....	36
3.11	Replacing the Hook Assembly.....	37
3.12	Replacing the Black Mark Sensor .....	38
3.13	Replacing the Head Open Sensor.....	39
3.14	Replacing the Media Holder .....	40
3.15	Installing the Wi-Fi/ Bluetooth Module .....	42
3.16	Installing the Cutter Module.....	45
3.17	Installing the Peel-off Module .....	47
3.18	Installing the Linerless Tear/Cutter Module.....	50

3.19	Installing the Narrow Media Adaptor.....	53
<b>4</b>	<b>Troubleshooting.....</b>	<b>56</b>
4.1	Common Problems.....	56
<b>5</b>	<b>Maintenance .....</b>	<b>61</b>
	<b>Revise History .....</b>	<b>64</b>

# 1 Introduction

Thank you very much for purchasing TSC bar code printer.

The DH220 series of thermal desktop barcode printers support more printing applications than any other printer in its class. The four-inch wide DH220 series can address everything from higher volume 4x6 shipping labels, higher resolution product marking and graphic solutions, to high resolution labels used in electronics marking applications.

The DH220 series features a user-friendly spring-loaded center-biased clamshell design for easy drop-in media loading of 5-inch rolls of media. The printer construction features a rugged double-wall design that is stronger and more durable than other thermal transfer mechanisms on the market. Its strong motor is powerful enough to handle a 300-meter-long ribbon.

As with all TSC printers, the DH220 Series features the TSPL-EZD printer-control language, which is fully compatible with other TSC printer languages, while supporting TPLE (Translation Printer Language Eltron®), TPLZ (Translation Printer Language Zebra®) and TPLD (Translation Printer Language Datamax®). The languages automatically decipher and translate the format of each label as it is sent to the printer. TSPL-EZD also features internal scalable True Type fonts (based on the Monotype® font engine), which are typically found only in more expensive printers.

This document provides an easy reference for operating this printer. TSC printers include the Windows labeling software for creating your label template. For system integration, the TSPL/TSPL2 printer programming manual or SDKs can be found on TSC website at: <https://www.tscprinters.com>.

# 1.1 Printer Features

## Front View

DH220 Series

DH220T Series

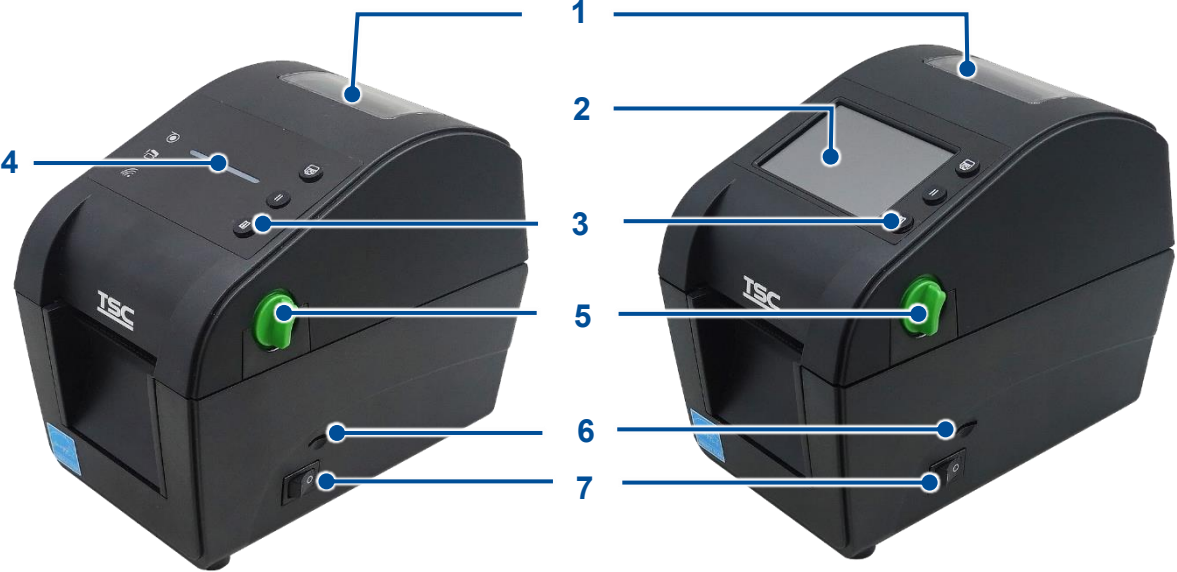

- 1. Media viewer window
- 2. LCD
- 3. Operating buttons
- 4. LED
- 5. Cover lever
- 6. microSD card slot
- 7. Power switch

# Interior View



- 1. Printhead
- 2. Upper black mark sensor
- 3. Media holder
- 4. Media cover holder lock
- 5. Media holder lock
- 6. Black mark sensor
- 7. Platen roller
- 8. Lower front panel

## Rear View



1. Power Jack
2. USB interface
3. USB host
4. RS-232C interface
5. Ethernet LAN port



# 2 Electronics

## 2.1 Summary of the Board Connectors

### Main board

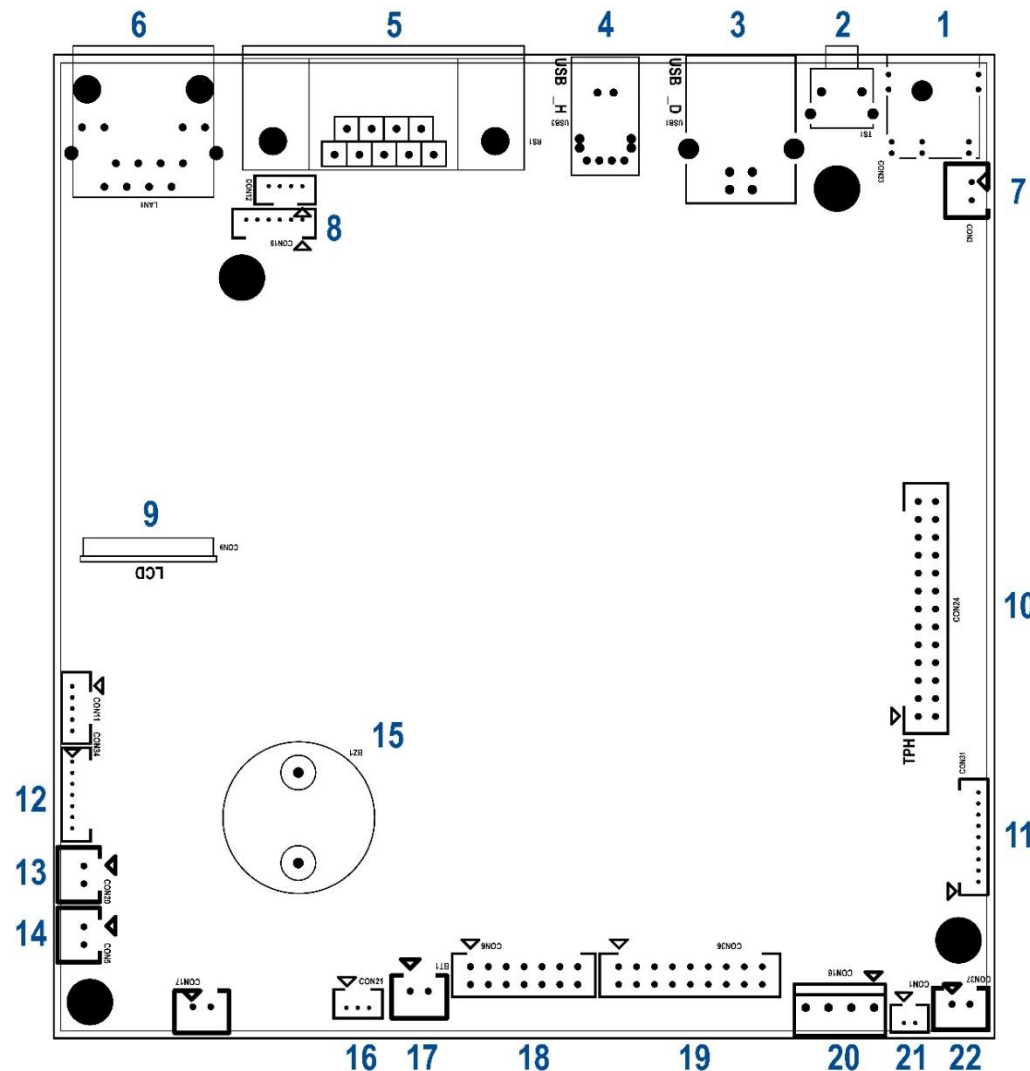

1. Power supply output (24V DC) connector
2. System reset switch
3. USB device connector
4. USB host connector
5. RS-232C connector
6. Ethernet connector
7. ESD cable connector
8. Panel touch and key connector
9. LCD connector
10. TPH connector
11. Micro SD card connector
12. NFC connector
13. Black mark sensor connector for print side (transmitter)
14. Black mark sensor connector for print side (receiver)
15. Buzzer
16. Black mark sensor connector for back side
17. Coin battery connector
18. Cutter / Peeler / RFID connector
19. Wi-Fi & Bluetooth connector
20. Stepping motor connector
21. Head open connector
22. Power switch connector

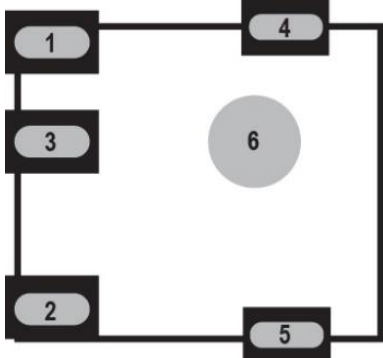
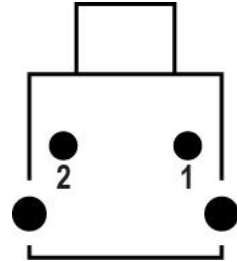
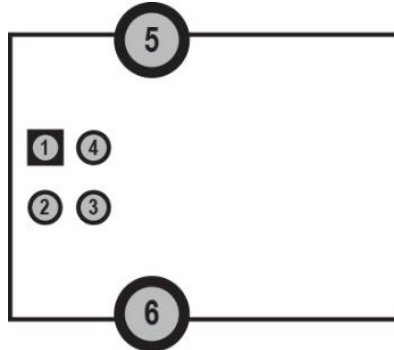
No.	Function	Pin Definition												
1	<p>Power supply output (24V DC) connector</p> 	<table border="1"> <thead> <tr> <th>No.</th> <th>Definition</th> </tr> </thead> <tbody> <tr> <td>1</td> <td>DCIN 24V</td> </tr> <tr> <td>2</td> <td>GND</td> </tr> <tr> <td>3</td> <td>GND</td> </tr> <tr> <td>4</td> <td>GND</td> </tr> <tr> <td>5</td> <td>GND</td> </tr> </tbody> </table>	No.	Definition	1	DCIN 24V	2	GND	3	GND	4	GND	5	GND
No.	Definition													
1	DCIN 24V													
2	GND													
3	GND													
4	GND													
5	GND													
2	<p>System reset switch (for resetting RTC or when printer hangs)</p> 	<table border="1"> <thead> <tr> <th>No.</th> <th>Definition</th> </tr> </thead> <tbody> <tr> <td>1</td> <td>Vbattery</td> </tr> <tr> <td>2</td> <td>VDDBU reset signal</td> </tr> </tbody> </table>	No.	Definition	1	Vbattery	2	VDDBU reset signal						
No.	Definition													
1	Vbattery													
2	VDDBU reset signal													
3	<p>USB device connector</p> 	<table border="1"> <thead> <tr> <th>No.</th> <th>Definition</th> </tr> </thead> <tbody> <tr> <td>1</td> <td>NC</td> </tr> <tr> <td>2</td> <td>D-</td> </tr> <tr> <td>3</td> <td>D+</td> </tr> <tr> <td>4</td> <td>GND</td> </tr> </tbody> </table>	No.	Definition	1	NC	2	D-	3	D+	4	GND		
No.	Definition													
1	NC													
2	D-													
3	D+													
4	GND													

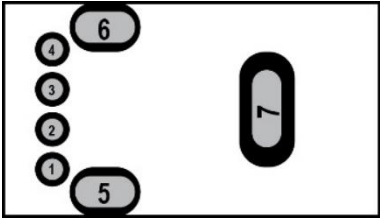
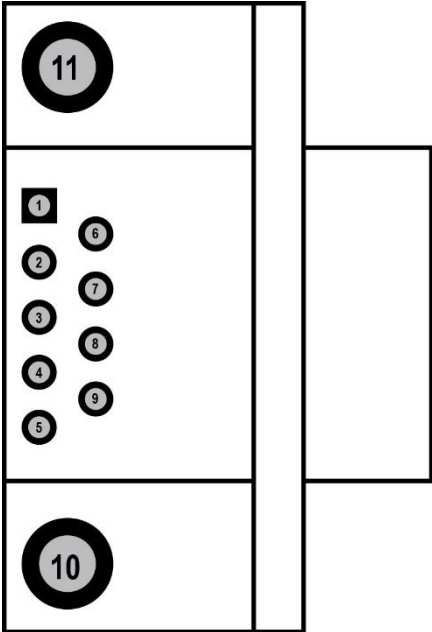
No.	Function	Pin Definition																				
4	USB host connector 	<table border="1"> <thead> <tr> <th>No.</th> <th>Definition</th> </tr> </thead> <tbody> <tr> <td>1</td> <td>VBUS 5V</td> </tr> <tr> <td>2</td> <td>D-</td> </tr> <tr> <td>3</td> <td>D+</td> </tr> <tr> <td>4</td> <td>GND</td> </tr> </tbody> </table>	No.	Definition	1	VBUS 5V	2	D-	3	D+	4	GND										
No.	Definition																					
1	VBUS 5V																					
2	D-																					
3	D+																					
4	GND																					
5	RS-232C connector 	<table border="1"> <thead> <tr> <th>No.</th> <th>Definition</th> </tr> </thead> <tbody> <tr> <td>1</td> <td>VBUS 5V</td> </tr> <tr> <td>2</td> <td>TXD</td> </tr> <tr> <td>3</td> <td>RXD</td> </tr> <tr> <td>4</td> <td>CTS</td> </tr> <tr> <td>5</td> <td>GND</td> </tr> <tr> <td>6</td> <td>RTS</td> </tr> <tr> <td>7</td> <td>NC</td> </tr> <tr> <td>8</td> <td>RTS</td> </tr> <tr> <td>9</td> <td>NC</td> </tr> </tbody> </table>	No.	Definition	1	VBUS 5V	2	TXD	3	RXD	4	CTS	5	GND	6	RTS	7	NC	8	RTS	9	NC
No.	Definition																					
1	VBUS 5V																					
2	TXD																					
3	RXD																					
4	CTS																					
5	GND																					
6	RTS																					
7	NC																					
8	RTS																					
9	NC																					

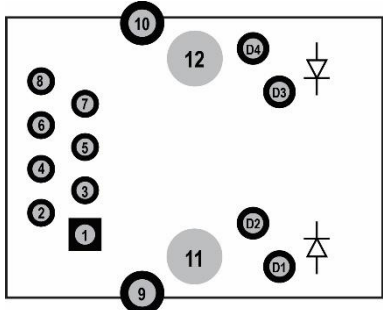
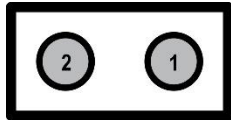
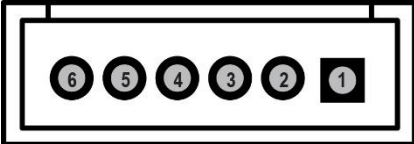
No.	Function	Pin Definition																										
6	Ethernet connector 	<table border="1"> <thead> <tr> <th>No.</th> <th>Definition</th> </tr> </thead> <tbody> <tr><td>1</td><td>TX+</td></tr> <tr><td>2</td><td>TX-</td></tr> <tr><td>3</td><td>RX+</td></tr> <tr><td>4</td><td>NC</td></tr> <tr><td>5</td><td>NC</td></tr> <tr><td>6</td><td>RX-</td></tr> <tr><td>7</td><td>NC</td></tr> <tr><td>8</td><td>FGND</td></tr> <tr><td>D1</td><td>3.3V</td></tr> <tr><td>D2</td><td>Green LED Control</td></tr> <tr><td>D3</td><td>Yellow LED Control</td></tr> <tr><td>D4</td><td>3.3V</td></tr> </tbody> </table>	No.	Definition	1	TX+	2	TX-	3	RX+	4	NC	5	NC	6	RX-	7	NC	8	FGND	D1	3.3V	D2	Green LED Control	D3	Yellow LED Control	D4	3.3V
No.	Definition																											
1	TX+																											
2	TX-																											
3	RX+																											
4	NC																											
5	NC																											
6	RX-																											
7	NC																											
8	FGND																											
D1	3.3V																											
D2	Green LED Control																											
D3	Yellow LED Control																											
D4	3.3V																											
7	ESD cable connector 	<table border="1"> <thead> <tr> <th>No.</th> <th>Definition</th> </tr> </thead> <tbody> <tr><td>1</td><td>GND</td></tr> <tr><td>2</td><td>GND</td></tr> </tbody> </table>	No.	Definition	1	GND	2	GND																				
No.	Definition																											
1	GND																											
2	GND																											
8	Panel touch and key connector 	<table border="1"> <thead> <tr> <th>No.</th> <th>Definition</th> </tr> </thead> <tbody> <tr><td>1</td><td>3.3V</td></tr> <tr><td>2</td><td>KEY_SDA</td></tr> <tr><td>3</td><td>KEY_SCL</td></tr> <tr><td>4</td><td>KEY_INT</td></tr> <tr><td>5</td><td>GND</td></tr> <tr><td>6</td><td>TOUCH_INT</td></tr> </tbody> </table>	No.	Definition	1	3.3V	2	KEY_SDA	3	KEY_SCL	4	KEY_INT	5	GND	6	TOUCH_INT												
No.	Definition																											
1	3.3V																											
2	KEY_SDA																											
3	KEY_SCL																											
4	KEY_INT																											
5	GND																											
6	TOUCH_INT																											

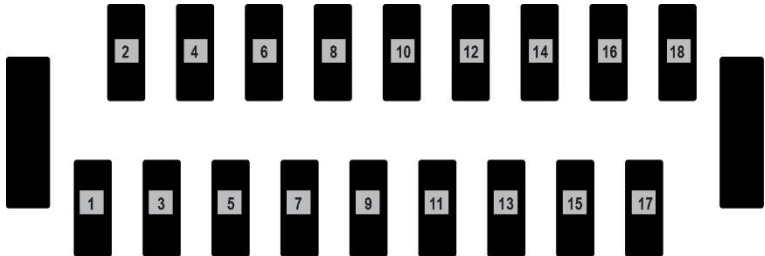
No.	Function	Pin Definition																																						
9	LCD connector 	<table border="1"> <thead> <tr> <th data-bbox="1220 271 1370 311">No.</th> <th data-bbox="1370 271 1899 311">Definition</th> </tr> </thead> <tbody> <tr><td data-bbox="1220 311 1370 351">1</td><td data-bbox="1370 311 1899 351">3.3V</td></tr> <tr><td data-bbox="1220 351 1370 391">2</td><td data-bbox="1370 351 1899 391">3.3V</td></tr> <tr><td data-bbox="1220 391 1370 430">3</td><td data-bbox="1370 391 1899 430">GND</td></tr> <tr><td data-bbox="1220 430 1370 470">4</td><td data-bbox="1370 430 1899 470">3.3V</td></tr> <tr><td data-bbox="1220 470 1370 510">5</td><td data-bbox="1370 470 1899 510">LCD_BL</td></tr> <tr><td data-bbox="1220 510 1370 550">6</td><td data-bbox="1370 510 1899 550">LCD_D/CX</td></tr> <tr><td data-bbox="1220 550 1370 590">7</td><td data-bbox="1370 550 1899 590">LCD_D0</td></tr> <tr><td data-bbox="1220 590 1370 630">8</td><td data-bbox="1370 590 1899 630">LCD_D1</td></tr> <tr><td data-bbox="1220 630 1370 670">9</td><td data-bbox="1370 630 1899 670">LCD_D2</td></tr> <tr><td data-bbox="1220 670 1370 710">10</td><td data-bbox="1370 670 1899 710">LCD_D3</td></tr> <tr><td data-bbox="1220 710 1370 750">11</td><td data-bbox="1370 710 1899 750">LCD_D4</td></tr> <tr><td data-bbox="1220 750 1370 790">12</td><td data-bbox="1370 750 1899 790">LCD_D5</td></tr> <tr><td data-bbox="1220 790 1370 829">13</td><td data-bbox="1370 790 1899 829">LCD_D6</td></tr> <tr><td data-bbox="1220 829 1370 869">14</td><td data-bbox="1370 829 1899 869">LCD_D7</td></tr> <tr><td data-bbox="1220 869 1370 909">15</td><td data-bbox="1370 869 1899 909">LCD_NCS</td></tr> <tr><td data-bbox="1220 909 1370 949">16</td><td data-bbox="1370 909 1899 949">LCD_RESET</td></tr> <tr><td data-bbox="1220 949 1370 989">17</td><td data-bbox="1370 949 1899 989">LCD_WE</td></tr> <tr><td data-bbox="1220 989 1370 1029">18</td><td data-bbox="1370 989 1899 1029">GND</td></tr> </tbody> </table>	No.	Definition	1	3.3V	2	3.3V	3	GND	4	3.3V	5	LCD_BL	6	LCD_D/CX	7	LCD_D0	8	LCD_D1	9	LCD_D2	10	LCD_D3	11	LCD_D4	12	LCD_D5	13	LCD_D6	14	LCD_D7	15	LCD_NCS	16	LCD_RESET	17	LCD_WE	18	GND
No.	Definition																																							
1	3.3V																																							
2	3.3V																																							
3	GND																																							
4	3.3V																																							
5	LCD_BL																																							
6	LCD_D/CX																																							
7	LCD_D0																																							
8	LCD_D1																																							
9	LCD_D2																																							
10	LCD_D3																																							
11	LCD_D4																																							
12	LCD_D5																																							
13	LCD_D6																																							
14	LCD_D7																																							
15	LCD_NCS																																							
16	LCD_RESET																																							
17	LCD_WE																																							
18	GND																																							

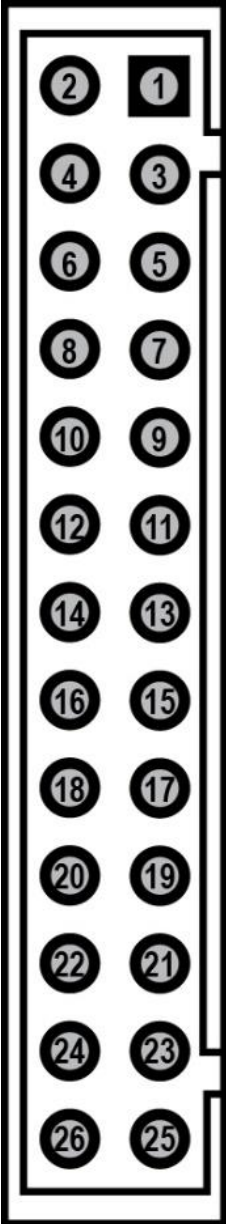
No.	Function	Pin Definition																																																						
10	TPH connector 	<table border="1"> <thead> <tr> <th data-bbox="1220 319 1370 359">No.</th> <th data-bbox="1370 319 1899 359">Definition</th> </tr> </thead> <tbody> <tr><td>1</td><td>TPH 24V</td></tr> <tr><td>2</td><td>TPH 24V</td></tr> <tr><td>3</td><td>TPH 24V</td></tr> <tr><td>4</td><td>TPH 24V</td></tr> <tr><td>5</td><td>GND</td></tr> <tr><td>6</td><td>GND</td></tr> <tr><td>7</td><td>Strobe2</td></tr> <tr><td>8</td><td>Data2</td></tr> <tr><td>9</td><td>TPH ID</td></tr> <tr><td>10</td><td>Temperature sensor</td></tr> <tr><td>11</td><td>5V</td></tr> <tr><td>12</td><td>GND</td></tr> <tr><td>13</td><td>Strobe1</td></tr> <tr><td>14</td><td>GND</td></tr> <tr><td>15</td><td>Clock</td></tr> <tr><td>16</td><td>GND</td></tr> <tr><td>17</td><td>GND</td></tr> <tr><td>18</td><td>GND</td></tr> <tr><td>19</td><td>Data1</td></tr> <tr><td>20</td><td>Latch</td></tr> <tr><td>21</td><td>GND</td></tr> <tr><td>22</td><td>GND</td></tr> <tr><td>23</td><td>TPH 24V</td></tr> <tr><td>24</td><td>TPH 24V</td></tr> <tr><td>25</td><td>TPH 24V</td></tr> <tr><td>26</td><td>TPH 24V</td></tr> </tbody> </table>	No.	Definition	1	TPH 24V	2	TPH 24V	3	TPH 24V	4	TPH 24V	5	GND	6	GND	7	Strobe2	8	Data2	9	TPH ID	10	Temperature sensor	11	5V	12	GND	13	Strobe1	14	GND	15	Clock	16	GND	17	GND	18	GND	19	Data1	20	Latch	21	GND	22	GND	23	TPH 24V	24	TPH 24V	25	TPH 24V	26	TPH 24V
	No.	Definition																																																						
1	TPH 24V																																																							
2	TPH 24V																																																							
3	TPH 24V																																																							
4	TPH 24V																																																							
5	GND																																																							
6	GND																																																							
7	Strobe2																																																							
8	Data2																																																							
9	TPH ID																																																							
10	Temperature sensor																																																							
11	5V																																																							
12	GND																																																							
13	Strobe1																																																							
14	GND																																																							
15	Clock																																																							
16	GND																																																							
17	GND																																																							
18	GND																																																							
19	Data1																																																							
20	Latch																																																							
21	GND																																																							
22	GND																																																							
23	TPH 24V																																																							
24	TPH 24V																																																							
25	TPH 24V																																																							
26	TPH 24V																																																							

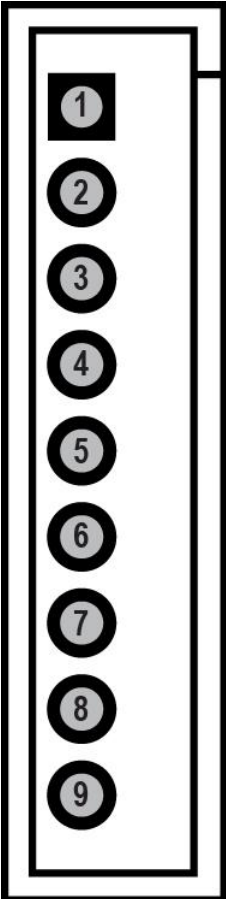
No.	Function	Pin Definition																				
11	Micro SD card connector 	<table border="1"> <thead> <tr> <th data-bbox="1220 486 1370 518">No.</th> <th data-bbox="1370 486 1899 518">Definition</th> </tr> </thead> <tbody> <tr> <td data-bbox="1220 518 1370 550">1</td> <td data-bbox="1370 518 1899 550">Micro_SD_DATA1</td> </tr> <tr> <td data-bbox="1220 550 1370 582">2</td> <td data-bbox="1370 550 1899 582">Micro_SD_DATA0</td> </tr> <tr> <td data-bbox="1220 582 1370 614">3</td> <td data-bbox="1370 582 1899 614">GND</td> </tr> <tr> <td data-bbox="1220 614 1370 646">4</td> <td data-bbox="1370 614 1899 646">Micro_SD_CLK</td> </tr> <tr> <td data-bbox="1220 646 1370 678">5</td> <td data-bbox="1370 646 1899 678">3.3V</td> </tr> <tr> <td data-bbox="1220 678 1370 710">6</td> <td data-bbox="1370 678 1899 710">Micro_SD_CMD</td> </tr> <tr> <td data-bbox="1220 710 1370 742">7</td> <td data-bbox="1370 710 1899 742">Micro_SD_DATA3</td> </tr> <tr> <td data-bbox="1220 742 1370 774">8</td> <td data-bbox="1370 742 1899 774">Micro_SD_DATA2</td> </tr> <tr> <td data-bbox="1220 774 1370 805">9</td> <td data-bbox="1370 774 1899 805">Micro_SD_DT</td> </tr> </tbody> </table>	No.	Definition	1	Micro_SD_DATA1	2	Micro_SD_DATA0	3	GND	4	Micro_SD_CLK	5	3.3V	6	Micro_SD_CMD	7	Micro_SD_DATA3	8	Micro_SD_DATA2	9	Micro_SD_DT
No.	Definition																					
1	Micro_SD_DATA1																					
2	Micro_SD_DATA0																					
3	GND																					
4	Micro_SD_CLK																					
5	3.3V																					
6	Micro_SD_CMD																					
7	Micro_SD_DATA3																					
8	Micro_SD_DATA2																					
9	Micro_SD_DT																					

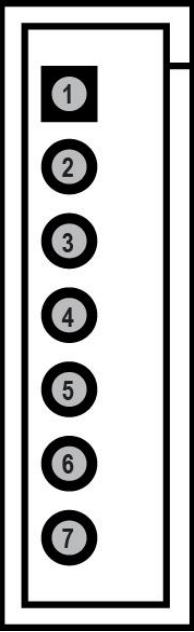
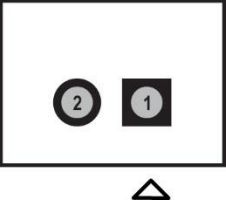
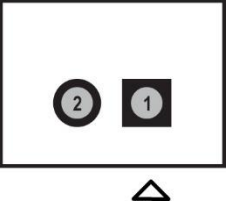
No.	Function	Pin Definition																
12	NFC connector 	<table border="1"> <thead> <tr> <th>No.</th> <th>Definition</th> </tr> </thead> <tbody> <tr> <td>1</td> <td>3.3V</td> </tr> <tr> <td>2</td> <td>NFC_TWD</td> </tr> <tr> <td>3</td> <td>NFC_TWCK</td> </tr> <tr> <td>4</td> <td>GND</td> </tr> <tr> <td>5</td> <td>NFC_RTS</td> </tr> <tr> <td>6</td> <td>NFC_CTS</td> </tr> <tr> <td>7</td> <td>NFC_UPDATE</td> </tr> </tbody> </table>	No.	Definition	1	3.3V	2	NFC_TWD	3	NFC_TWCK	4	GND	5	NFC_RTS	6	NFC_CTS	7	NFC_UPDATE
No.	Definition																	
1	3.3V																	
2	NFC_TWD																	
3	NFC_TWCK																	
4	GND																	
5	NFC_RTS																	
6	NFC_CTS																	
7	NFC_UPDATE																	
13	Black mark sensor connector for print side (transmitter) 	<table border="1"> <thead> <tr> <th>No.</th> <th>Definition</th> </tr> </thead> <tbody> <tr> <td>1</td> <td>3.3V</td> </tr> <tr> <td>2</td> <td>Black Mark Sensor for Print Side (transmitter)</td> </tr> </tbody> </table>	No.	Definition	1	3.3V	2	Black Mark Sensor for Print Side (transmitter)										
No.	Definition																	
1	3.3V																	
2	Black Mark Sensor for Print Side (transmitter)																	
14	Black mark sensor connector for print side (receiver) 	<table border="1"> <thead> <tr> <th>No.</th> <th>Definition</th> </tr> </thead> <tbody> <tr> <td>1</td> <td>NC</td> </tr> <tr> <td>2</td> <td>Black Mark Sensor for Print Side (receiver)</td> </tr> </tbody> </table>	No.	Definition	1	NC	2	Black Mark Sensor for Print Side (receiver)										
No.	Definition																	
1	NC																	
2	Black Mark Sensor for Print Side (receiver)																	

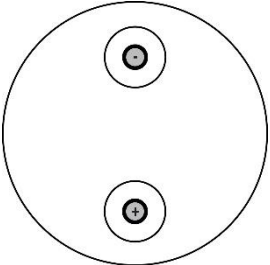
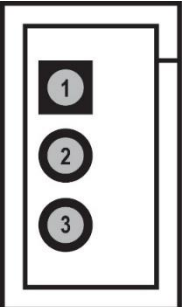
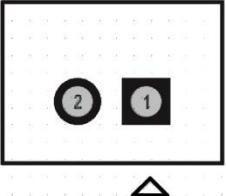

No.	Function	Pin Definition								
15	Buzzer 	<table border="1"> <thead> <tr> <th>No.</th> <th>Definition</th> </tr> </thead> <tbody> <tr> <td>+</td> <td>SYS 24V</td> </tr> <tr> <td>-</td> <td>Buzzer control</td> </tr> </tbody> </table>	No.	Definition	+	SYS 24V	-	Buzzer control		
No.	Definition									
+	SYS 24V									
-	Buzzer control									
16	Black mark sensor connector 	<table border="1"> <thead> <tr> <th>No.</th> <th>Definition</th> </tr> </thead> <tbody> <tr> <td>1</td> <td>Black Mark Sensor Receiver</td> </tr> <tr> <td>2</td> <td>Black Mark Sensor Emitter</td> </tr> <tr> <td>3</td> <td>3.3V</td> </tr> </tbody> </table>	No.	Definition	1	Black Mark Sensor Receiver	2	Black Mark Sensor Emitter	3	3.3V
No.	Definition									
1	Black Mark Sensor Receiver									
2	Black Mark Sensor Emitter									
3	3.3V									
17	Coin battery connector 	<table border="1"> <thead> <tr> <th>No.</th> <th>Definition</th> </tr> </thead> <tbody> <tr> <td>1</td> <td>Vbattery</td> </tr> <tr> <td>2</td> <td>GND</td> </tr> </tbody> </table>	No.	Definition	1	Vbattery	2	GND		
No.	Definition									
1	Vbattery									
2	GND									

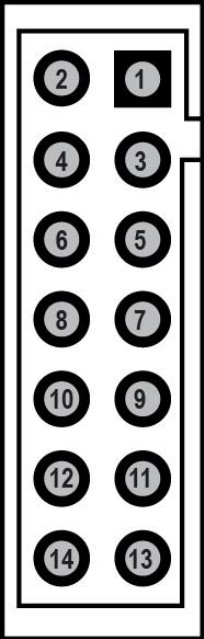
No.	Function	Pin Definition																													
18	Cutter / Peeler / RFID connector																														
		<table border="1"> <thead> <tr> <th data-bbox="1220 268 1370 304">No.</th> <th data-bbox="1370 268 1899 304">Definition</th> </tr> </thead> <tbody> <tr> <td data-bbox="1220 304 1370 341">1</td> <td data-bbox="1370 304 1899 341">CRFID_RXD</td> </tr> <tr> <td data-bbox="1220 341 1370 378">2</td> <td data-bbox="1370 341 1899 378">CRFID_TXD</td> </tr> <tr> <td data-bbox="1220 378 1370 414">3</td> <td data-bbox="1370 378 1899 414">5V_RFID</td> </tr> <tr> <td data-bbox="1220 414 1370 451">4</td> <td data-bbox="1370 414 1899 451">GND</td> </tr> <tr> <td data-bbox="1220 451 1370 488">5</td> <td data-bbox="1370 451 1899 488">Peeler_TWD</td> </tr> <tr> <td data-bbox="1220 488 1370 525">6</td> <td data-bbox="1370 488 1899 525">Peeler sensor receiver</td> </tr> <tr> <td data-bbox="1220 525 1370 561">7</td> <td data-bbox="1370 525 1899 561">5V_Cutter</td> </tr> <tr> <td data-bbox="1220 561 1370 598">8</td> <td data-bbox="1370 561 1899 598">Peeler_TWCK</td> </tr> <tr> <td data-bbox="1220 598 1370 635">9</td> <td data-bbox="1370 598 1899 635">Cutter rotate direction</td> </tr> <tr> <td data-bbox="1220 635 1370 671">10</td> <td data-bbox="1370 635 1899 671">Cutter enable signal</td> </tr> <tr> <td data-bbox="1220 671 1370 708">11</td> <td data-bbox="1370 671 1899 708">GND</td> </tr> <tr> <td data-bbox="1220 708 1370 745">12</td> <td data-bbox="1370 708 1899 745">Cutter status</td> </tr> <tr> <td data-bbox="1220 745 1370 782">13</td> <td data-bbox="1370 745 1899 782">GND</td> </tr> <tr> <td data-bbox="1220 782 1370 818">14</td> <td data-bbox="1370 782 1899 818">24V</td> </tr> </tbody> </table>	No.	Definition	1	CRFID_RXD	2	CRFID_TXD	3	5V_RFID	4	GND	5	Peeler_TWD	6	Peeler sensor receiver	7	5V_Cutter	8	Peeler_TWCK	9	Cutter rotate direction	10	Cutter enable signal	11	GND	12	Cutter status	13	GND	14
No.	Definition																														
1	CRFID_RXD																														
2	CRFID_TXD																														
3	5V_RFID																														
4	GND																														
5	Peeler_TWD																														
6	Peeler sensor receiver																														
7	5V_Cutter																														
8	Peeler_TWCK																														
9	Cutter rotate direction																														
10	Cutter enable signal																														
11	GND																														
12	Cutter status																														
13	GND																														
14	24V																														

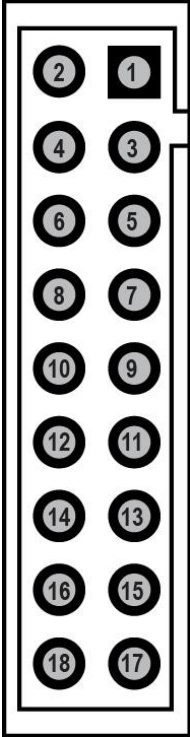
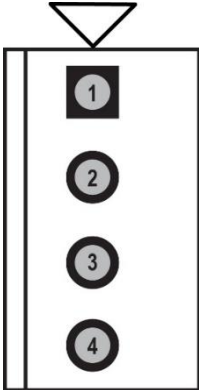
No.	Function	Pin Definition																																						
19	Wi-Fi & Bluetooth connector 	<table border="1"> <thead> <tr> <th data-bbox="1218 236 1370 276">No.</th> <th data-bbox="1370 236 1899 276">Definition</th> </tr> </thead> <tbody> <tr><td>1</td><td>GND</td></tr> <tr><td>2</td><td>3.3V_WIFI</td></tr> <tr><td>3</td><td>WIFI/ BT Detect</td></tr> <tr><td>4</td><td>WIFI_RX0</td></tr> <tr><td>5</td><td>WIFI_RX1</td></tr> <tr><td>6</td><td>WIFI_RXDV</td></tr> <tr><td>7</td><td>WIFI_REFCK</td></tr> <tr><td>8</td><td>GND</td></tr> <tr><td>9</td><td>WIFI_WAKEUP</td></tr> <tr><td>10</td><td>WIFI_TXEN</td></tr> <tr><td>11</td><td>WIFI_TX0</td></tr> <tr><td>12</td><td>WIFI_TX1</td></tr> <tr><td>13</td><td>BT_TXD</td></tr> <tr><td>14</td><td>BT_CTS</td></tr> <tr><td>15</td><td>BT_RXD</td></tr> <tr><td>16</td><td>BT_RTS</td></tr> <tr><td>17</td><td>3.3V_WIFI</td></tr> <tr><td>18</td><td>WIFI_RESET</td></tr> </tbody> </table>	No.	Definition	1	GND	2	3.3V_WIFI	3	WIFI/ BT Detect	4	WIFI_RX0	5	WIFI_RX1	6	WIFI_RXDV	7	WIFI_REFCK	8	GND	9	WIFI_WAKEUP	10	WIFI_TXEN	11	WIFI_TX0	12	WIFI_TX1	13	BT_TXD	14	BT_CTS	15	BT_RXD	16	BT_RTS	17	3.3V_WIFI	18	WIFI_RESET
No.	Definition																																							
1	GND																																							
2	3.3V_WIFI																																							
3	WIFI/ BT Detect																																							
4	WIFI_RX0																																							
5	WIFI_RX1																																							
6	WIFI_RXDV																																							
7	WIFI_REFCK																																							
8	GND																																							
9	WIFI_WAKEUP																																							
10	WIFI_TXEN																																							
11	WIFI_TX0																																							
12	WIFI_TX1																																							
13	BT_TXD																																							
14	BT_CTS																																							
15	BT_RXD																																							
16	BT_RTS																																							
17	3.3V_WIFI																																							
18	WIFI_RESET																																							
20	Stepping motor connector 	<table border="1"> <thead> <tr> <th data-bbox="1218 1161 1370 1201">Pin No.</th> <th data-bbox="1370 1161 1899 1201">Definition</th> </tr> </thead> <tbody> <tr><td>1</td><td>BOUT2</td></tr> <tr><td>2</td><td>BOUT1</td></tr> <tr><td>3</td><td>AOUT1</td></tr> <tr><td>4</td><td>AOUT2</td></tr> </tbody> </table>	Pin No.	Definition	1	BOUT2	2	BOUT1	3	AOUT1	4	AOUT2																												
Pin No.	Definition																																							
1	BOUT2																																							
2	BOUT1																																							
3	AOUT1																																							
4	AOUT2																																							

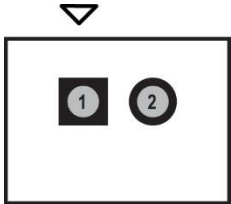
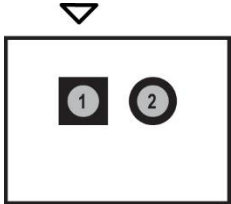
No.	Function	Pin Definition					
21	Head open connector						
		<table border="1"> <thead> <tr> <th data-bbox="1218 280 1370 320">Pin No.</th> <th data-bbox="1370 280 1899 320">Definition</th> </tr> </thead> <tbody> <tr> <td data-bbox="1218 320 1370 360">1</td> <td data-bbox="1370 320 1899 360">Head open sensor (receiver)</td> </tr> <tr> <td data-bbox="1218 360 1370 400">2</td> <td data-bbox="1370 360 1899 400">GND</td> </tr> </tbody> </table>	Pin No.	Definition	1	Head open sensor (receiver)	2
Pin No.	Definition						
1	Head open sensor (receiver)						
2	GND						
22	Power switch connector						
		<table border="1"> <thead> <tr> <th data-bbox="1218 572 1370 612">Pin No.</th> <th data-bbox="1370 572 1899 612">Definition</th> </tr> </thead> <tbody> <tr> <td data-bbox="1218 612 1370 652">1</td> <td data-bbox="1370 612 1899 652">EN_24V</td> </tr> <tr> <td data-bbox="1218 652 1370 692">2</td> <td data-bbox="1370 652 1899 692">SW_24V</td> </tr> </tbody> </table>	Pin No.	Definition	1	EN_24V	2
Pin No.	Definition						
1	EN_24V						
2	SW_24V						

## 2.2 Interface Pin Configuration

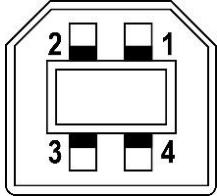
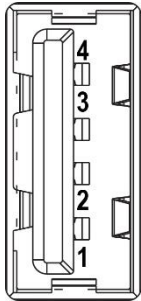
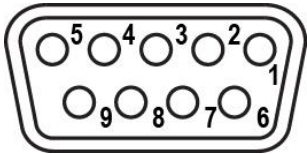
No.	Function	Pin Configuration																			
1	USB device																				
		<table border="1"> <thead> <tr> <th>No.</th> <th>Configuration</th> </tr> </thead> <tbody> <tr> <td>1</td> <td>NC</td> </tr> <tr> <td>2</td> <td>D-</td> </tr> <tr> <td>3</td> <td>D+</td> </tr> <tr> <td>4</td> <td>GND</td> </tr> </tbody> </table>	No.	Configuration	1	NC	2	D-	3	D+	4	GND									
No.	Configuration																				
1	NC																				
2	D-																				
3	D+																				
4	GND																				
2	USB host																				
		<table border="1"> <thead> <tr> <th>No.</th> <th>Configuration</th> </tr> </thead> <tbody> <tr> <td>1</td> <td>5V</td> </tr> <tr> <td>2</td> <td>D-</td> </tr> <tr> <td>3</td> <td>D+</td> </tr> <tr> <td>4</td> <td>GND</td> </tr> </tbody> </table>	No.	Configuration	1	5V	2	D-	3	D+	4	GND									
No.	Configuration																				
1	5V																				
2	D-																				
3	D+																				
4	GND																				
3	RS-232C																				
		<table border="1"> <thead> <tr> <th>No.</th> <th>Configuration</th> </tr> </thead> <tbody> <tr> <td>1</td> <td>+5V</td> </tr> <tr> <td>2</td> <td>TXD</td> </tr> <tr> <td>3</td> <td>RXD</td> </tr> <tr> <td>4</td> <td>CTS</td> </tr> <tr> <td>5</td> <td>GND</td> </tr> <tr> <td>6</td> <td>RTS</td> </tr> <tr> <td>7</td> <td>NC</td> </tr> <tr> <td>8</td> <td>RTS</td> </tr> <tr> <td>9</td> <td>NC</td> </tr> </tbody> </table>	No.	Configuration	1	+5V	2	TXD	3	RXD	4	CTS	5	GND	6	RTS	7	NC	8	RTS	9
No.	Configuration																				
1	+5V																				
2	TXD																				
3	RXD																				
4	CTS																				
5	GND																				
6	RTS																				
7	NC																				
8	RTS																				
9	NC																				

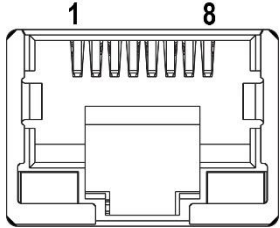
No.	Function	Pin Configuration																		
4	Ethernet LAN port  	<table border="1"> <thead> <tr> <th data-bbox="1220 279 1368 320">No.</th> <th data-bbox="1368 279 1899 320">Definition</th> </tr> </thead> <tbody> <tr> <td data-bbox="1220 320 1368 362">1</td> <td data-bbox="1368 320 1899 362">Tx+</td> </tr> <tr> <td data-bbox="1220 362 1368 403">2</td> <td data-bbox="1368 362 1899 403">Tx-</td> </tr> <tr> <td data-bbox="1220 403 1368 445">3</td> <td data-bbox="1368 403 1899 445">Rx+</td> </tr> <tr> <td data-bbox="1220 445 1368 486">4</td> <td data-bbox="1368 445 1899 486">NC</td> </tr> <tr> <td data-bbox="1220 486 1368 528">5</td> <td data-bbox="1368 486 1899 528">NC</td> </tr> <tr> <td data-bbox="1220 528 1368 569">6</td> <td data-bbox="1368 528 1899 569">Rx-</td> </tr> <tr> <td data-bbox="1220 569 1368 611">7</td> <td data-bbox="1368 569 1899 611">NC</td> </tr> <tr> <td data-bbox="1220 611 1368 652">8</td> <td data-bbox="1368 611 1899 652">NC</td> </tr> </tbody> </table>	No.	Definition	1	Tx+	2	Tx-	3	Rx+	4	NC	5	NC	6	Rx-	7	NC	8	NC
No.	Definition																			
1	Tx+																			
2	Tx-																			
3	Rx+																			
4	NC																			
5	NC																			
6	Rx-																			
7	NC																			
8	NC																			

# 3 Replacing Parts

## 3.1 Before You Begin

**WARNING:**

**To avoid the risk of personal injury from electrical shock, before performing any replacement procedures, unplug the power cord from the printer or power outlet to ensure that power is removed.**

To prepare the printer for the replacement or installation:

1. Protect yourself from ESD and wear protective gloves.
2. Place the printer on a flat surface.
3. Set the printer's power switch to the O (Off) position.
4. Remove the power adapter from the printer or unplug the power cord from the AC power outlet.
5. Disconnect all interface cables from the rear panel of the printer.
6. Remove the media from the printer.
7. Read through the maintenance procedures.

## 3.2 Replacing the Platen Roller Assembly

1. Follow the steps in [Before You Begin](#) to prepare the printer.
2. Open the printer cover by pulling the green levers, located on each side, toward the front of the printer, then lift the printer cover.
3. Remove the lower front panel as shown.

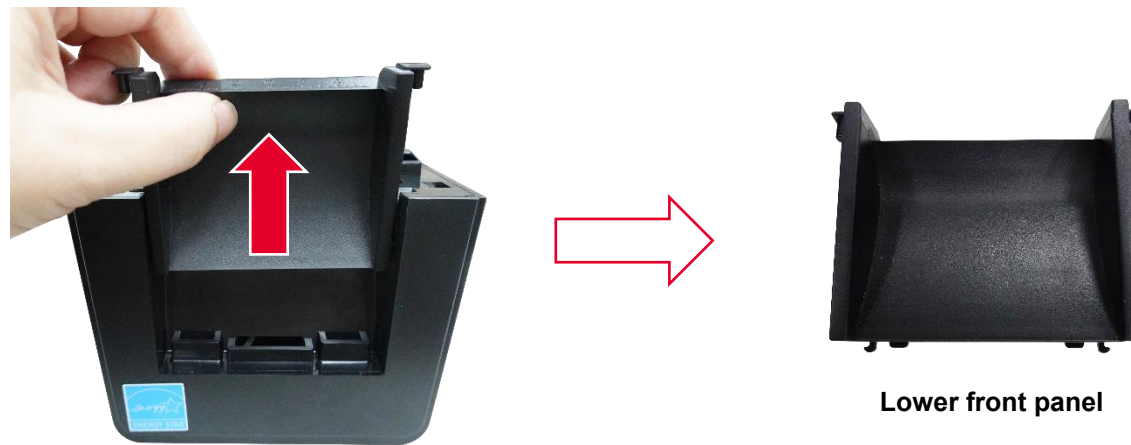

4. Rotate the two tabs of the platen roller to the indicated position.

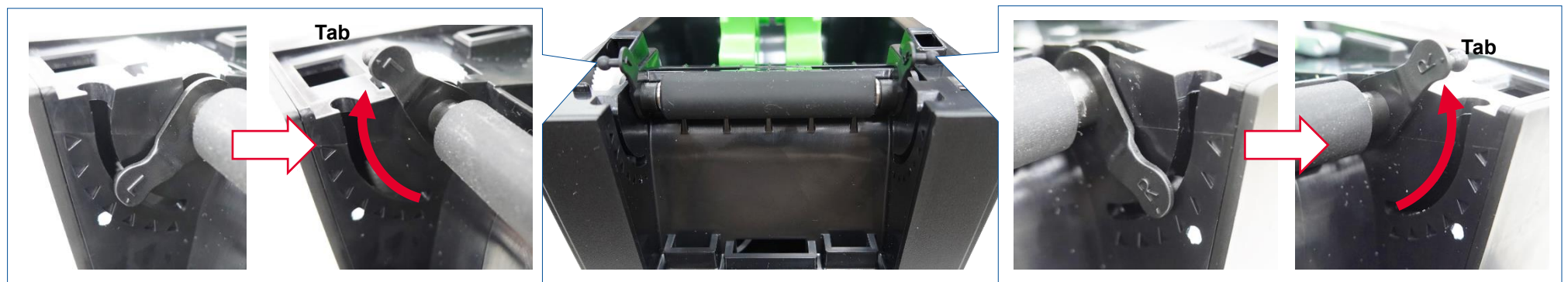



5. Pulling upward to remove/ replace the platen roller assembly.

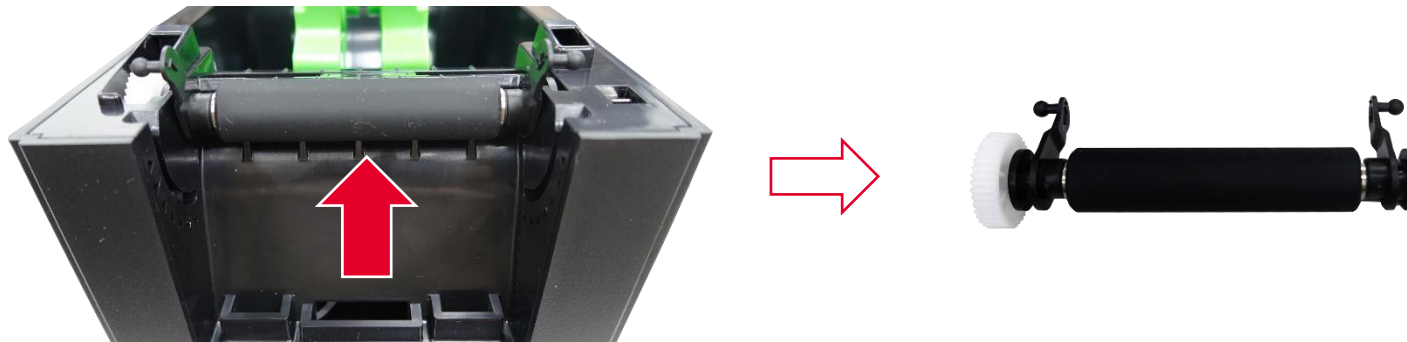

6. Reassemble the parts in the reverse procedure.

**Note:**

The default position of the platen roller tab is shown below (with a mark).

**Default setting**

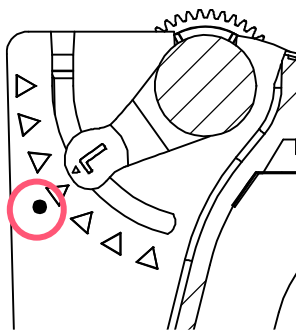

### 3.3 Replacing the Printhead & Upper Black Mark Sensor

**CAUTION:**

To prevent electrostatic damage to electronic components, ground yourself by touching an unpainted part of the printer frame before removing or installing the printhead assembly.

1. Follow the steps in [Before You Begin](#) to prepare the printer.
2. Open the printer cover by pulling the green levers, located on each side, toward the front of the printer, then lift the printer cover.
3. Slide the printhead assembly down while pressing and holding the latch to disengage it from inner cover.

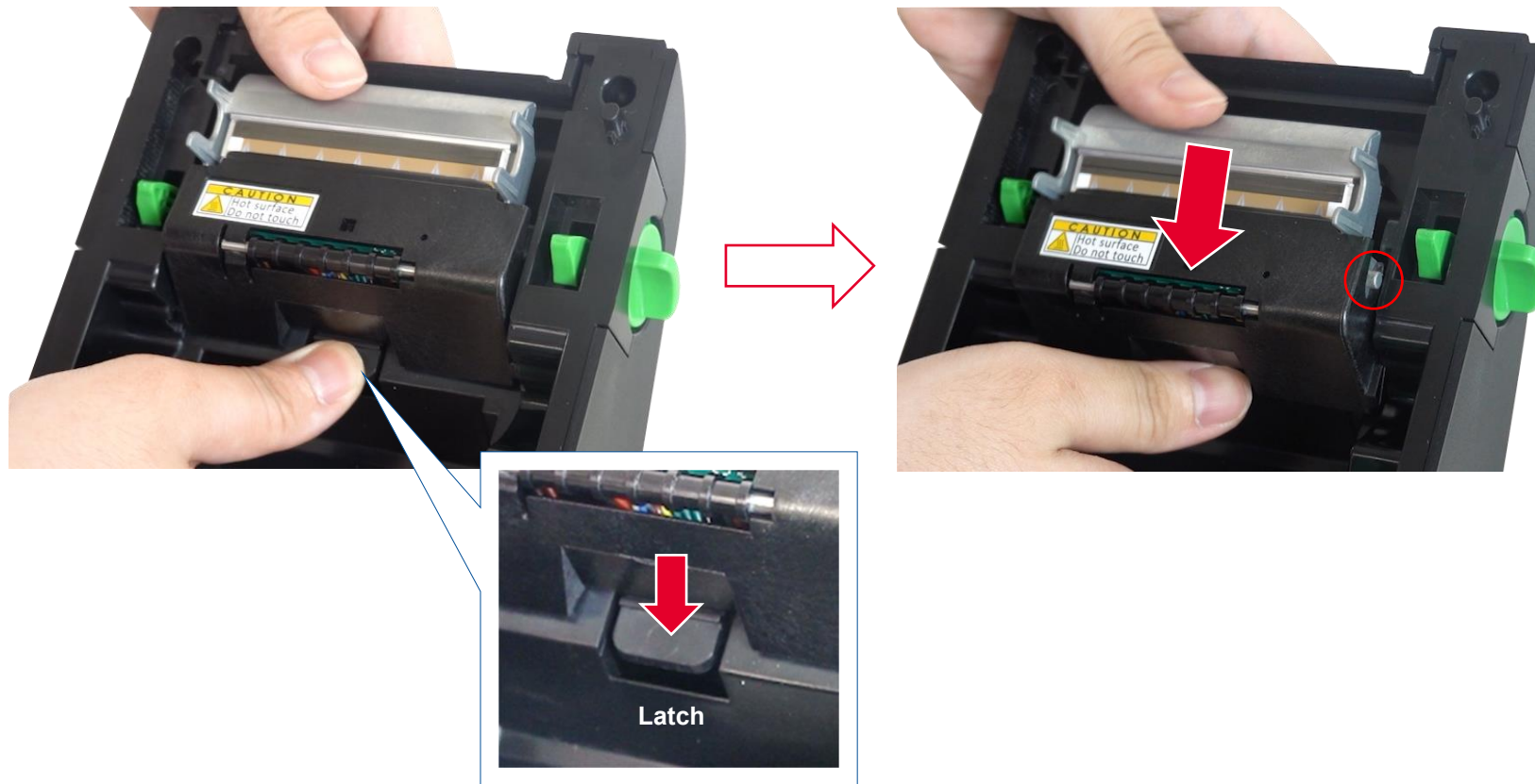

4. Slide the cover down. Disconnect the upper black mark sensor connector to remove the cover.

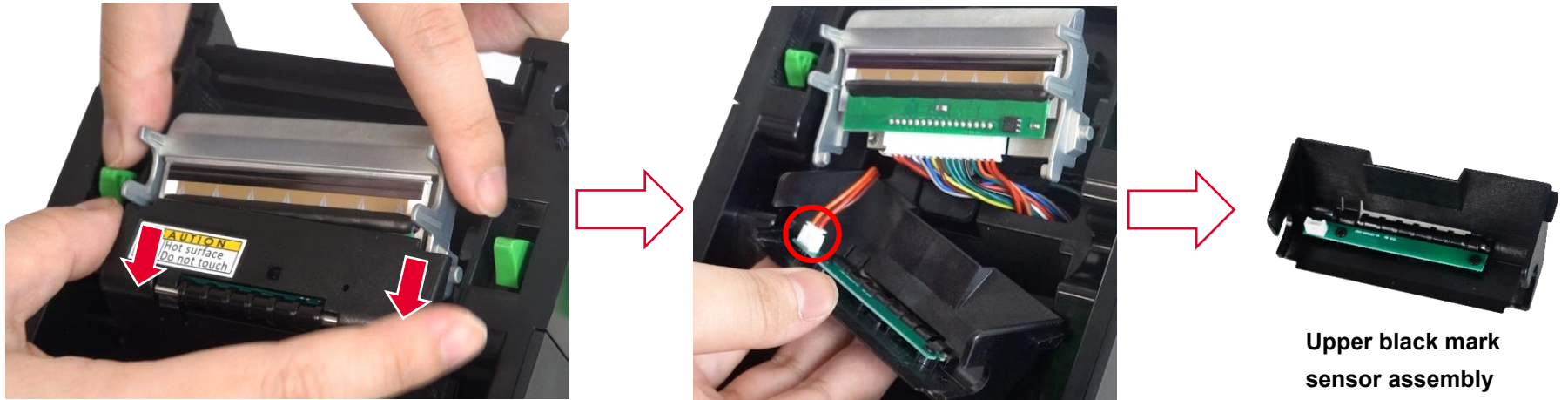

5. Disconnect the printhead harness and the ground wire. Remove/ Replace the printhead assembly.

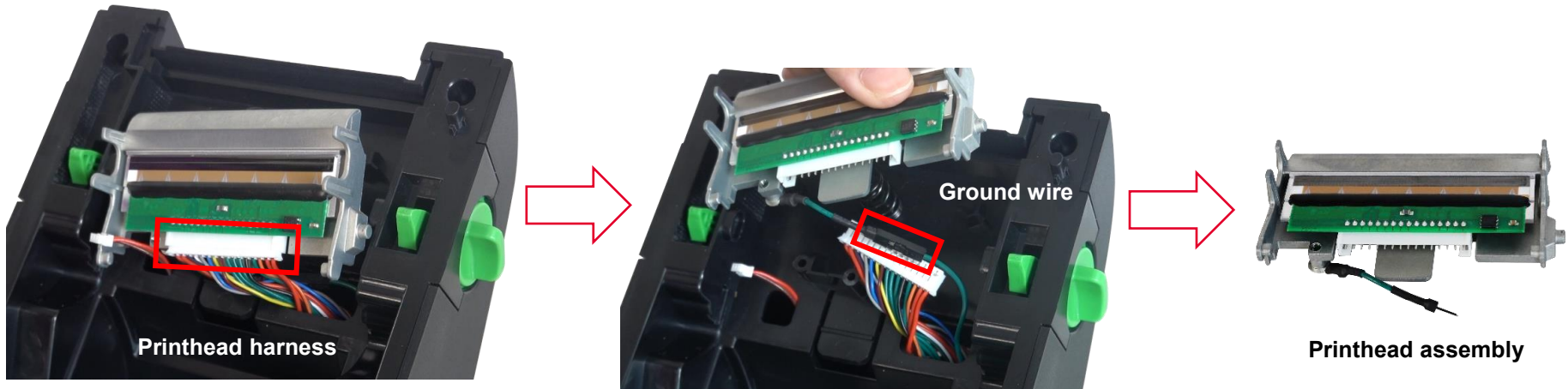

**CAUTION:**

Oils from your hands can damage the light brown area (heating elements) of the printhead. Do not touch the light brown area when you handle the printhead assembly.

6. Reassemble the parts in the reverse procedures.

## 3.4 Replacing the Top Cover

1. Follow the steps in [Before You Begin](#) to prepare the printer.
2. Open the printer cover by pulling the green levers, located on each side, toward the front of the printer, then lift the printer cover.
3. Remove four screws on the printer top inner cover as shown below. Remove/replace the printer top cover. Reassemble the parts in the reverse procedures.



**Note:** If your printer is equipped with a wireless module (Wi-Fi or Bluetooth) with LED version, please note that the NFC tag should be installed back into the LED top cover. (For LCD version, the NFC tag is in the LCD module bracket.)

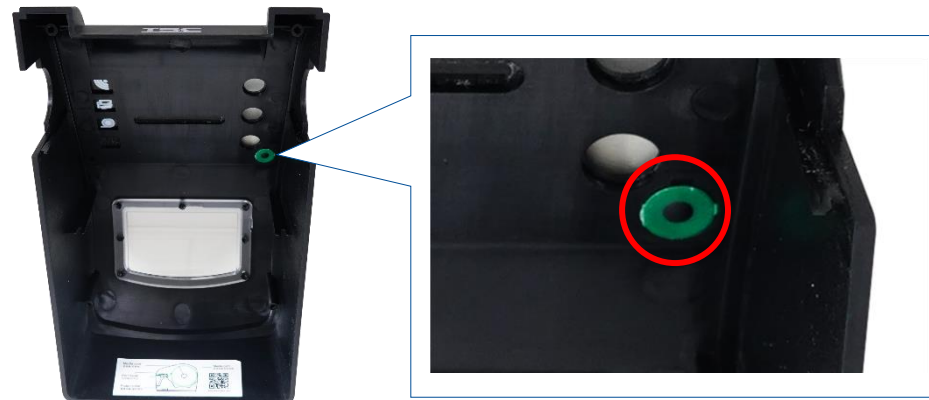

## 3.5 Replacing the Control Panel Assembly

1. Follow the steps in [Before You Begin](#) to prepare the printer.
2. Refer to [Replacing the Top Cover](#) to remove the printer top cover.
3. For LCD version (For LED version, go to the next step), remove two screws on LCD bracket and one connector as shown below.



Disconnect two flat cables on back of LCD control panel board. For flat cable, press the plug(s) to unlock it from connector on the control panel board, and carefully pull the flat cable free (do not pull on the wires; pull on the plug only).

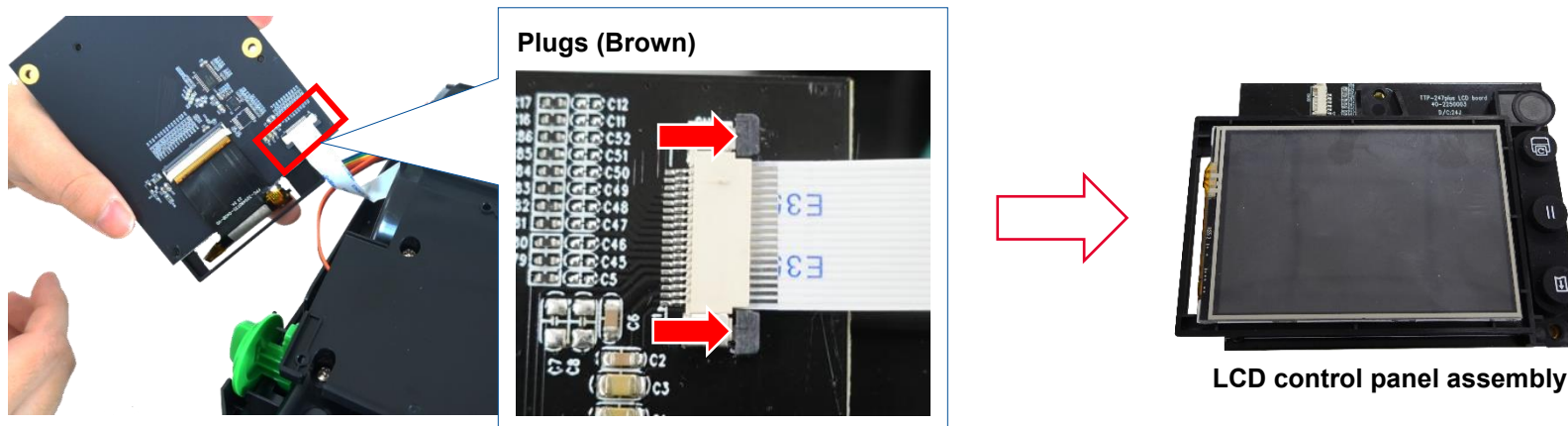



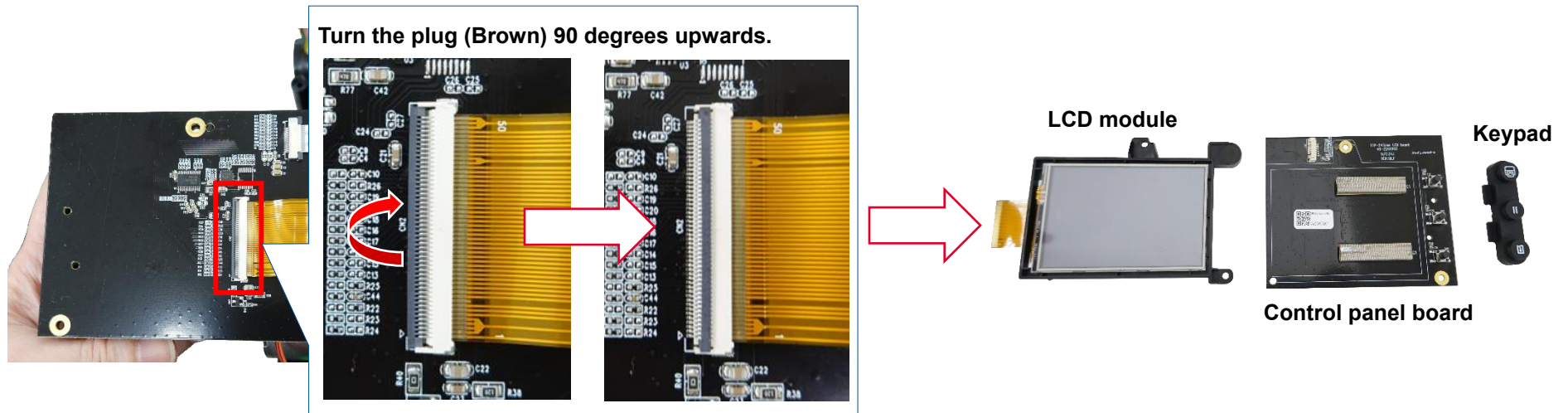

**Note:**

- ◆ When installing the control panel assembly, the ground cable must be secured underneath the control panel bracket.



- ◆ If your printer is equipped with a wireless module (Wi-Fi or Bluetooth), please note that the NFC tag should be installed back into the LCD module bracket.



4. For LED version, remove three screws and one connector on LED board as shown below. Remove two screws on back of LED board to replace the LED bar and the keypad.

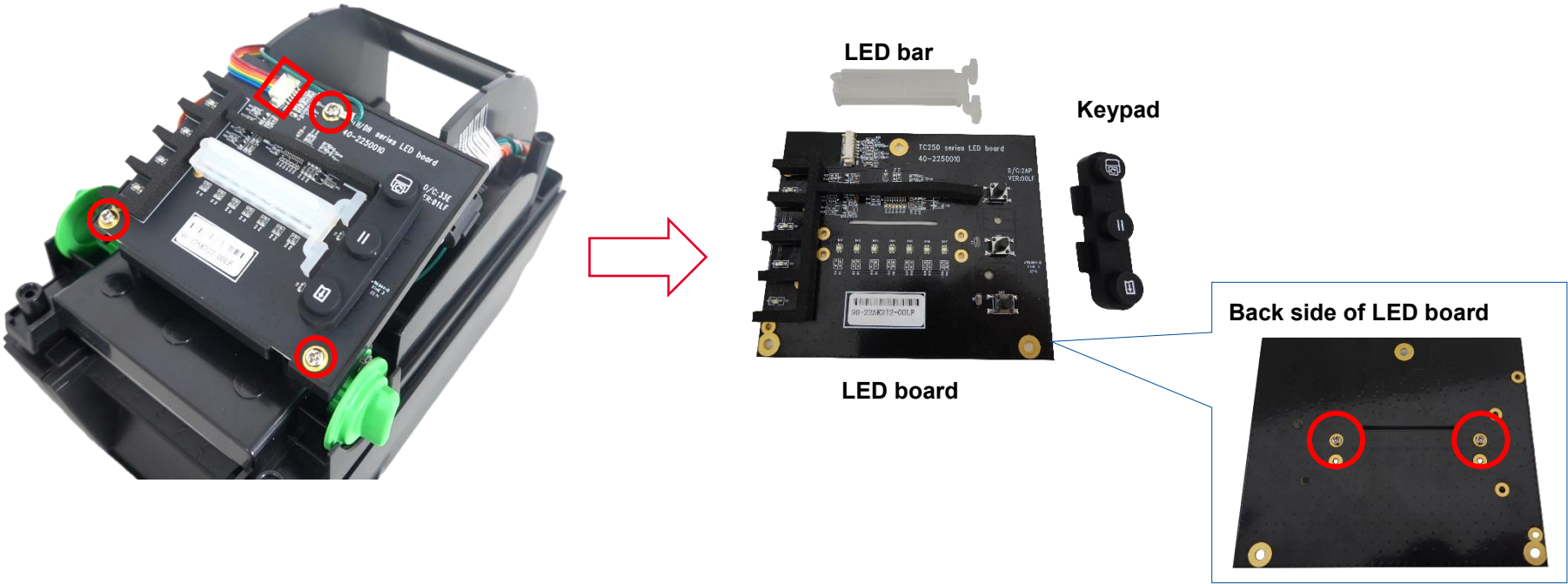

5. Reassemble the parts in the reverse procedures.

## 3.6 Replacing the Lower Cover

1. Follow the steps in [Before You Begin](#) to prepare the printer.
2. Remove two screws on the rear of printer to remove the interface cover.



3. Put the printer upside down. Remove one screw on the RTC cover to disconnect the RTC connector from main board first. (disconnect the Wi-Fi or MFi BT cable if installed.) Remove the cover.



**RTC connector  
(dotted line: Wireless connector position)**

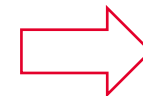
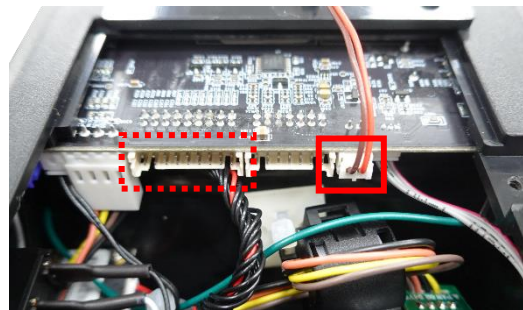

**Cover with RTC module**



4. Remove four screws on the printer lower cover. Remove the lower cover to disconnect the power switch connector (blue).



5. Reassemble the parts in the reverse procedures.

## 3.7 Replacing the RTC Module

1. Follow the steps in [Before You Begin](#) to prepare the printer.
2. Put the printer upside down. Remove one screw on the RTC module to disconnect the RTC cable from main board.

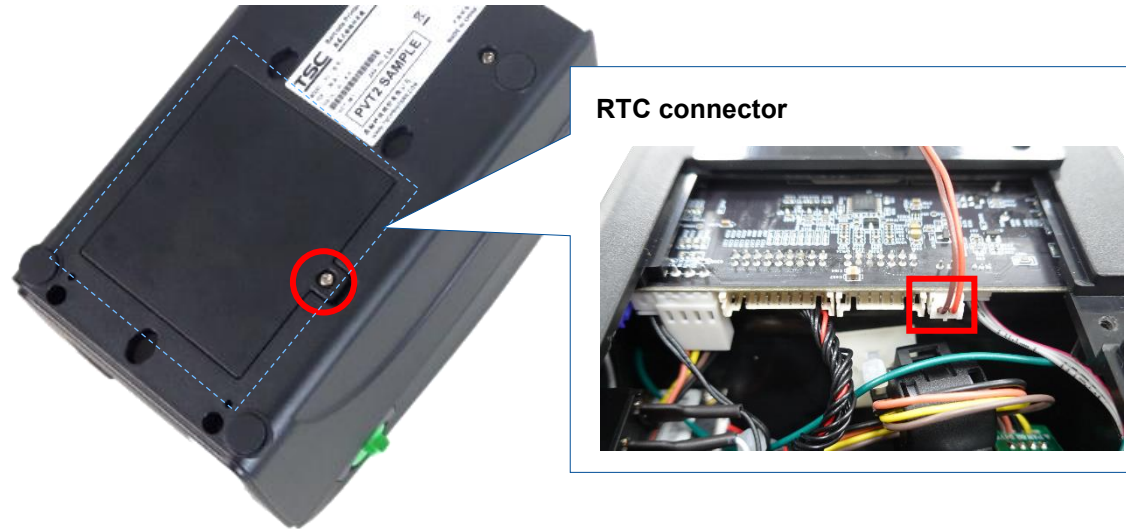

3. Remove/ Replace the RTC module. Please note that RTC battery (CR2032) is not included in the RTC module kit. Reassemble the parts in the reverse procedures.

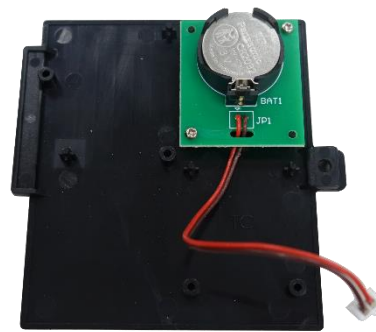

RTC module

### Note:

Press the tab to release the battery in the direction shown in the figure below.

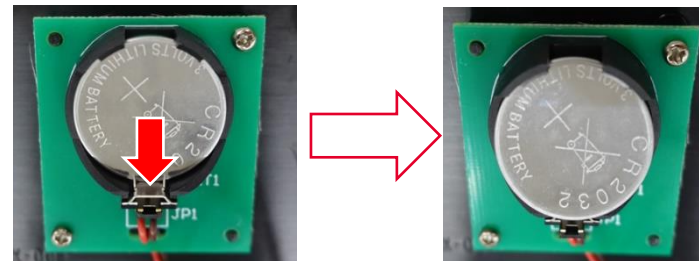

## 3.8 Replacing the Main Board

1. Follow the steps in [Before You Begin](#) to prepare the printer.
2. Refer to [Replacing the Lower Cover](#) to remove the printer lower cover.

### CAUTION

To prevent electrostatic damage to electronic components, always wear a properly grounded static wrist strap when you handle circuit boards.

3. Remove one screw on main board. Unplug all cable assemblies from the main board. Remove/ Replace the main board.

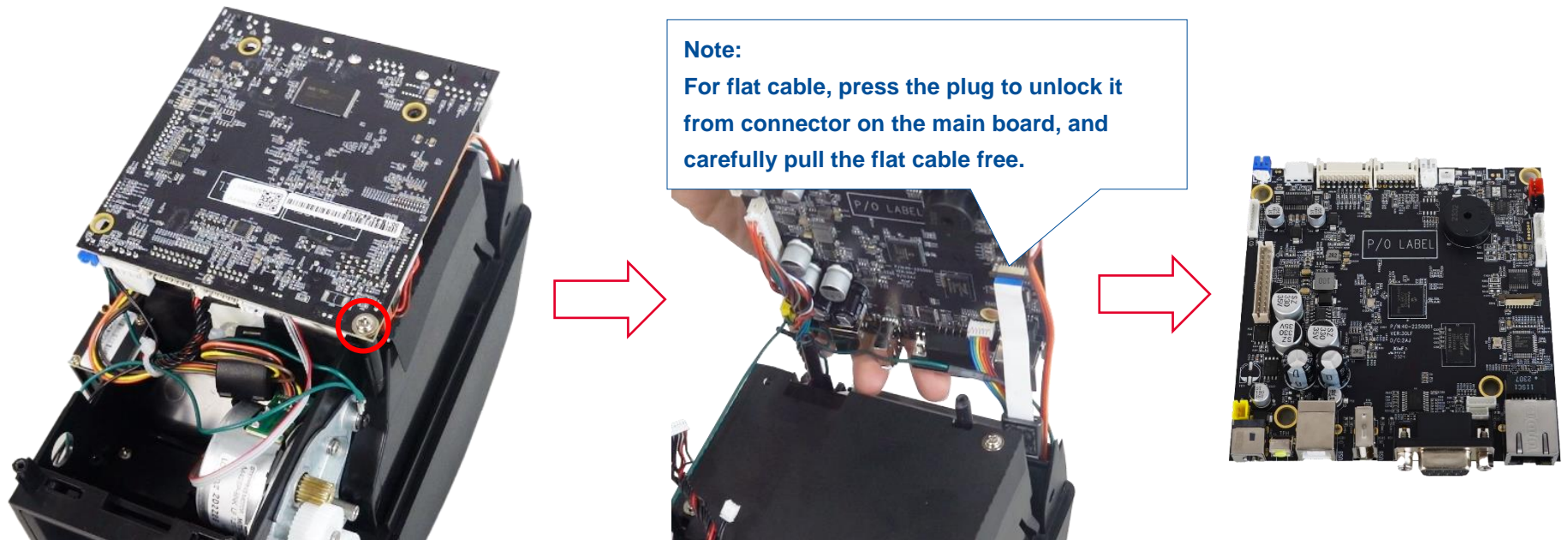

4. Reverse the steps of the removal procedure.

## 3.9 Replacing the SD Card Board

1. Follow the steps in [Before You Begin](#) to prepare the printer.
2. Remove the SD card, if one is installed, from the SD card slot.
3. Refer to [Replacing the Lower Cover](#) to remove the printer lower cover.
4. Remove two screws on SD card board. Unplug one cable connector from the SD card board. Remove/ Replace the SD card board.

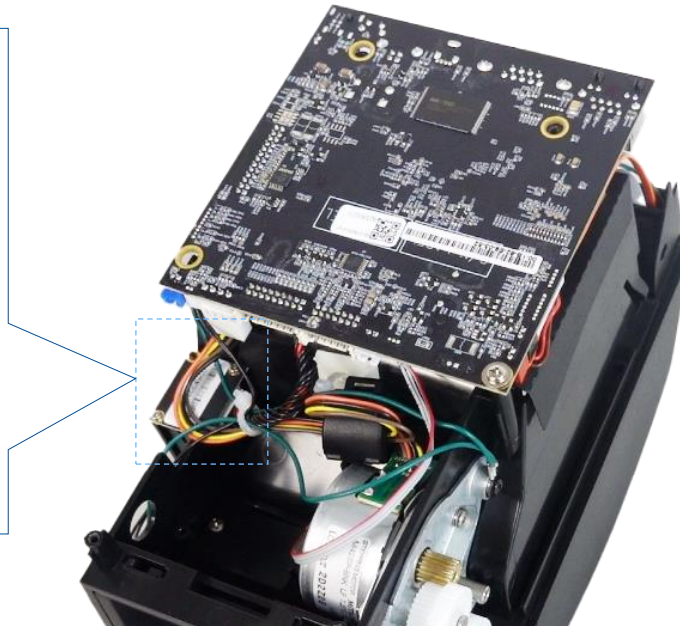
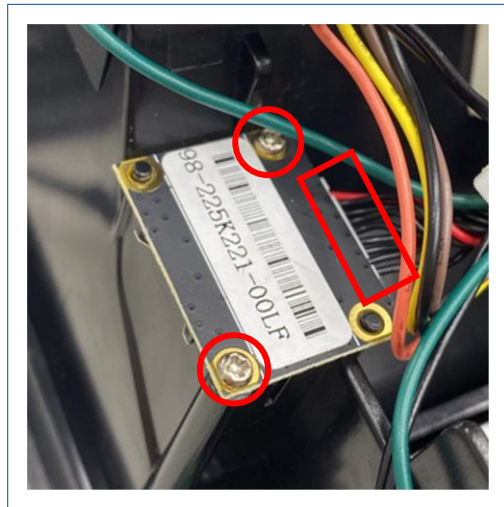

5. Reverse the steps of the removal procedure.



## 3.10 Replacing the Stepping Motor

1. Follow the steps in [Before You Begin](#) to prepare the printer.
2. Refer to [Replacing the Lower Cover](#) to remove the printer lower cover.
3. Disconnect the stepping motor connector from the main board. Remove two cable ties as shown.

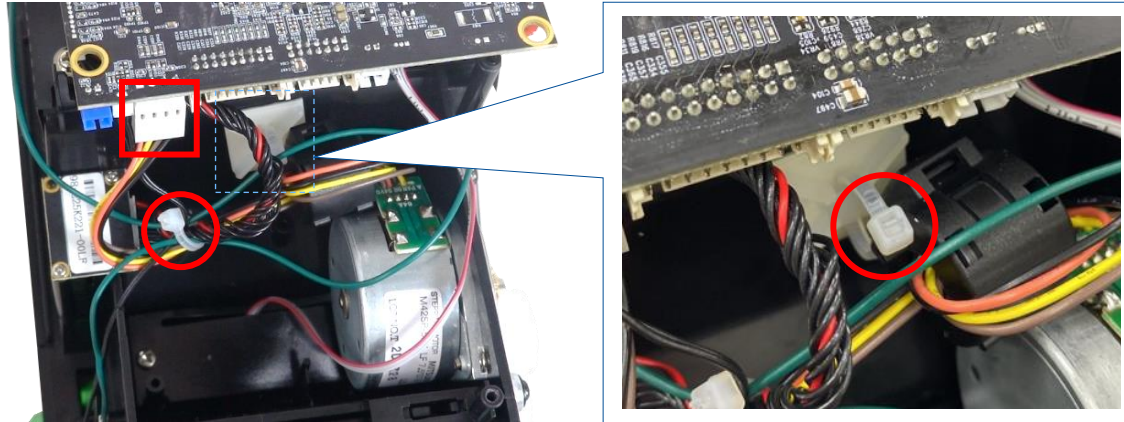

4. Remove two screws securing the stepping motor to the base of the printer frame. Remove/ Replace the stepping motor.



5. Reverse the steps of the removal procedure.

## 3.11 Replacing the Hook Assembly

1. Follow the steps in [Before You Begin](#) to prepare the printer.
2. Refer to [Replacing the Top Cover](#) to remove the printer top cover.
3. Remove the control panel assembly. For how to remove the control panel assembly, refer to [Replacing the Control Panel Assembly](#).
4. Remove the four screws securing the hook assembly cover in place and then remove the hook assembly cover.

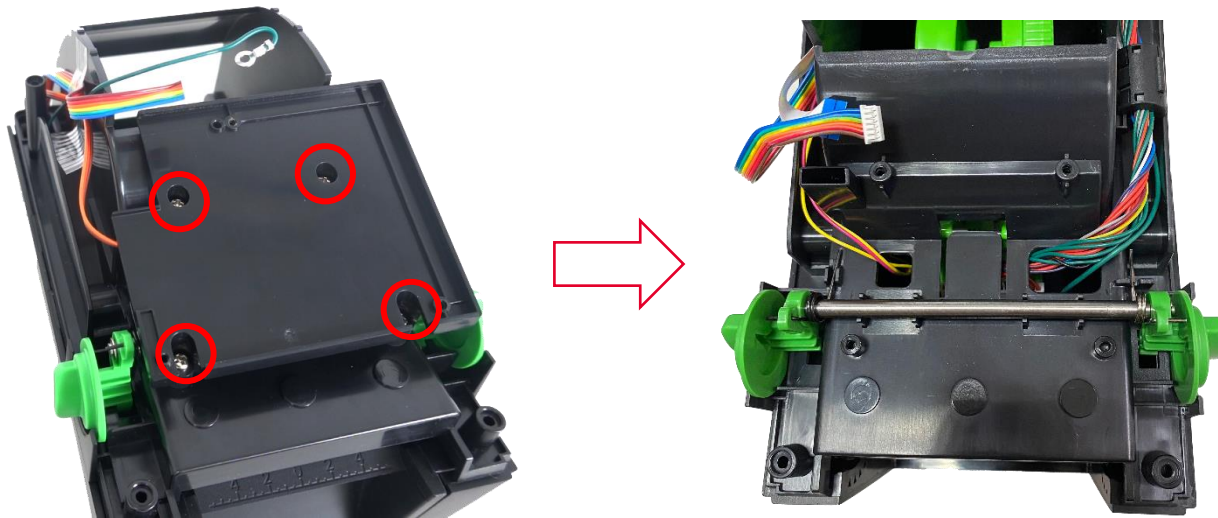

5. Release the two springs from their rib on the chassis and then remove the hook assembly from the printer. Reverse the steps of the removal procedure.

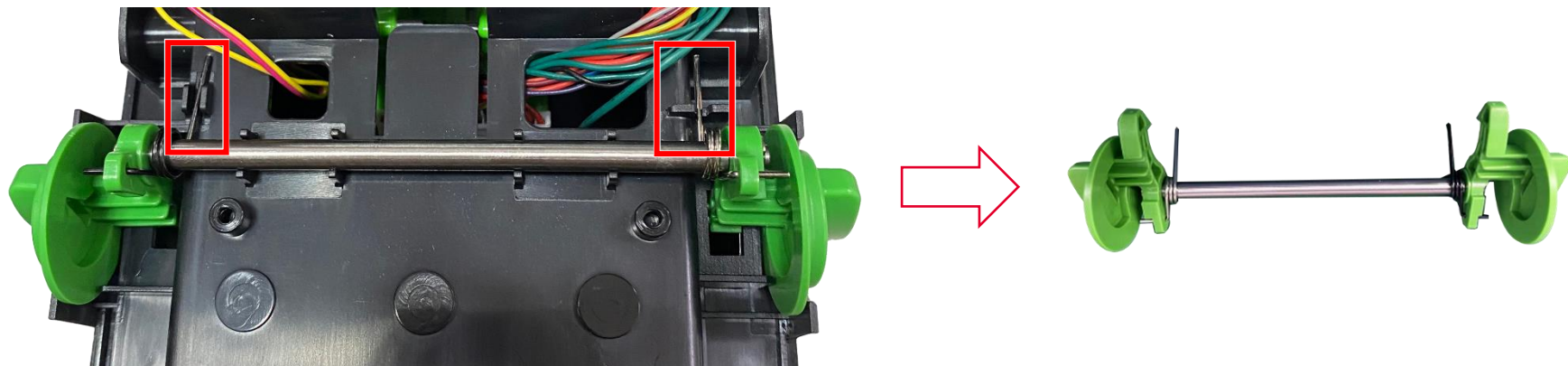

## 3.12 Replacing the Black Mark Sensor

1. Follow the steps in [Before You Begin](#) to prepare the printer.
2. Refer to [Replacing the Stepping Motor](#) to remove the stepping motor.
3. Remove two screws to remove the mylar.

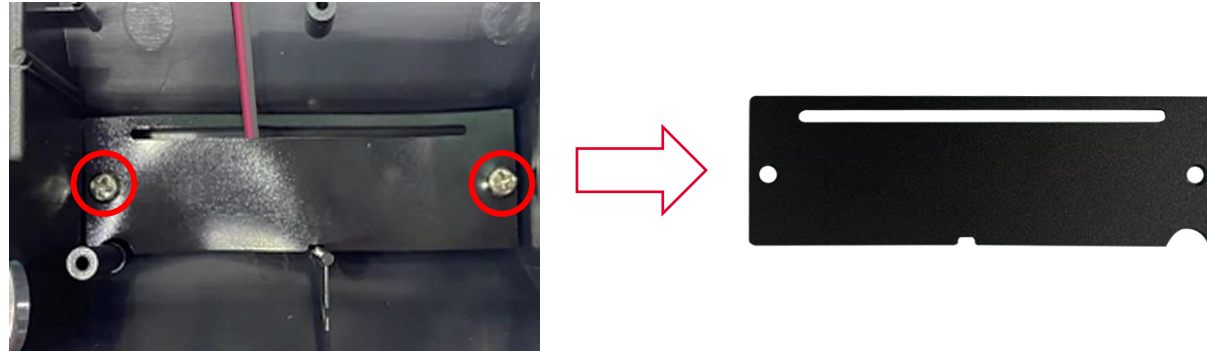

4. Disconnect the black mark sensor cable connector and remove one screw securing black mark sensor to the fixing plate.



5. Remove/ Replace the black mark sensor. Reverse the steps of the removal procedure.

## 3.13 Replacing the Head Open Sensor

1. Follow the steps in [Before You Begin](#) to prepare the printer.
2. Refer to [Replacing the Lower Cover](#) to remove the printer lower cover.
3. Remove one screw securing head open sensor to the printer frame. Refer to the [Replacing the Main Board](#) to disconnect the head open sensor cable connector from main board. Remove cable tie as shown.

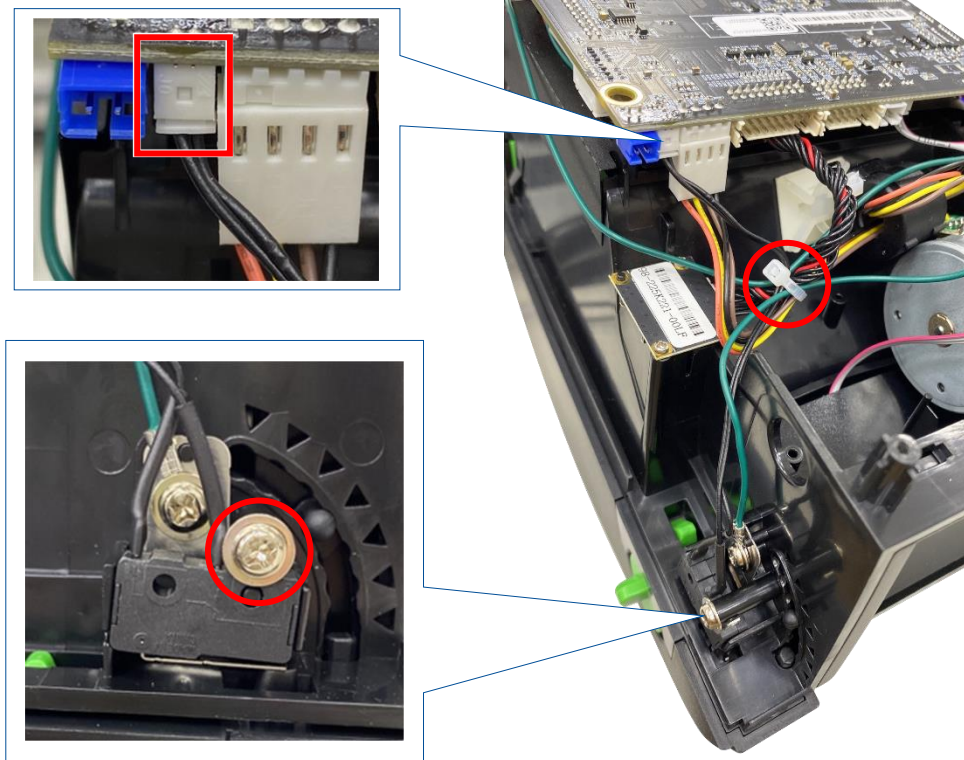

4. Remove/ Replace the head open sensor. Reverse the steps of the removal procedure.



### 3.14 Replacing the Media Holder

1. Follow the steps in [Before You Begin](#) to prepare the printer.
2. Refer to [Replacing the Main Board](#) to remove the main board.
3. Remove two screws to remove the mylar.

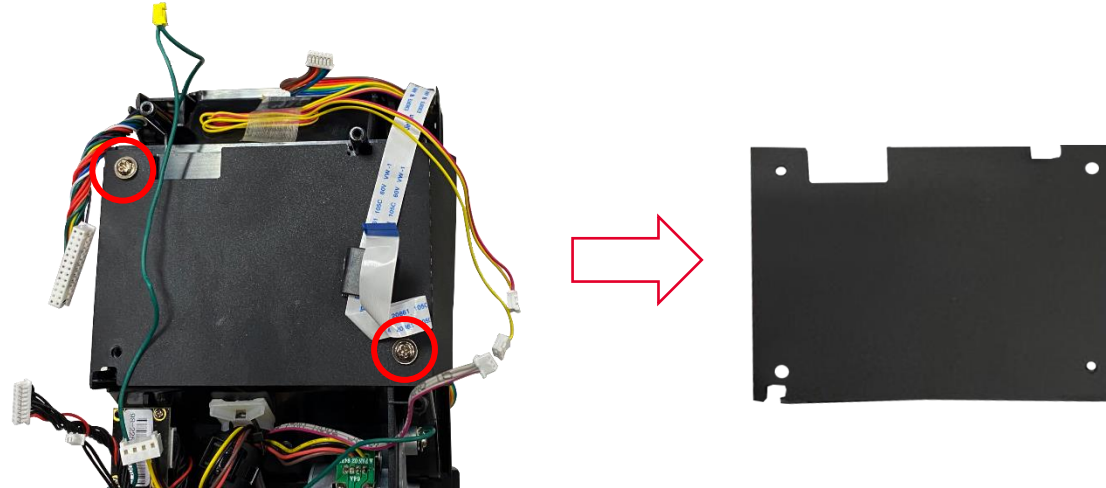

4. Use a tool to release the spring as shown below.

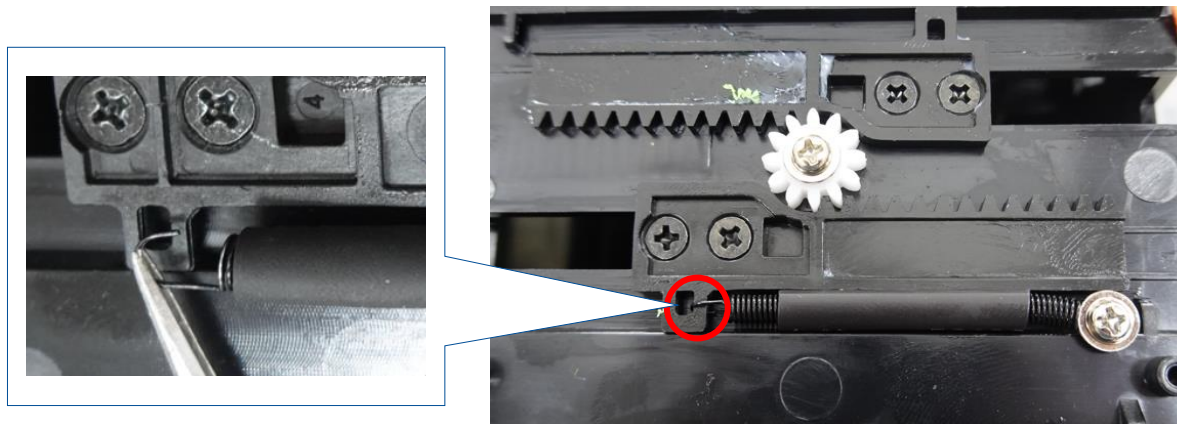

5. Remove the four screws securing the media holders in place and then replace the media holders. Reverse the steps of the removal procedure.

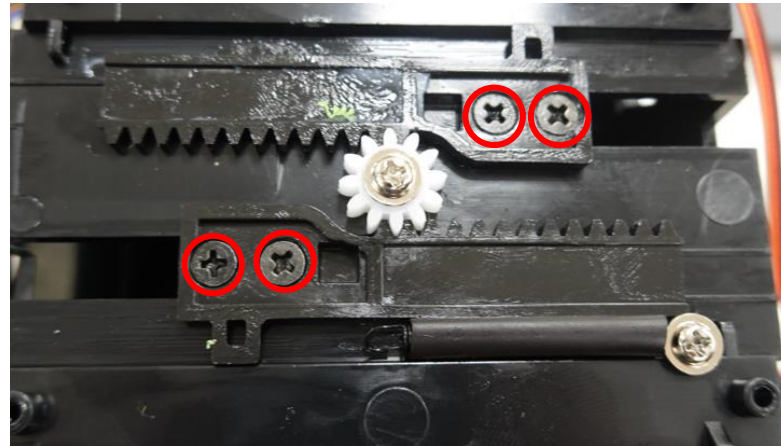

### 3.15 Installing the Wi-Fi/ Bluetooth Module

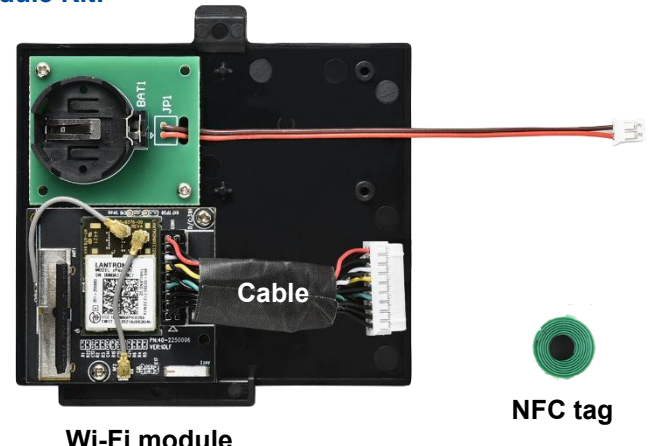
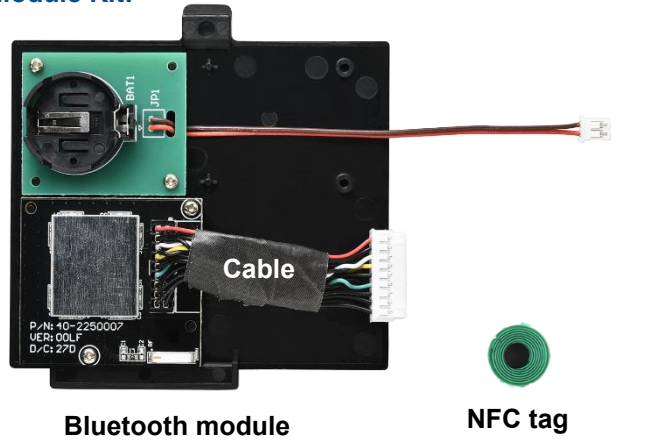
<p><b>Wi-Fi Module Kit:</b></p>  <p>The image shows the back of a printer housing with a green Wi-Fi module board installed. A red cable is connected to the board. A black cable is also connected to the board. A green NFC tag is shown next to the module.</p> <p><b>Wi-Fi module</b></p> <p><b>NFC tag</b></p>	<p><b>Bluetooth Module Kit:</b></p>  <p>The image shows the back of a printer housing with a green Bluetooth module board installed. A red cable is connected to the board. A black cable is also connected to the board. A green NFC tag is shown next to the module.</p> <p><b>Bluetooth module</b></p> <p><b>NFC tag</b></p>
<p><b>Note:</b> The Wi-Fi module and the Bluetooth module are installed in the same way, and this section mainly demonstrates the Wi-Fi module.</p>	

1. Follow the steps in [Before You Begin](#) to prepare the printer.
2. Put the printer upside down. Remove one screw as shown to disconnect RTC connector. Remove the RTC module.

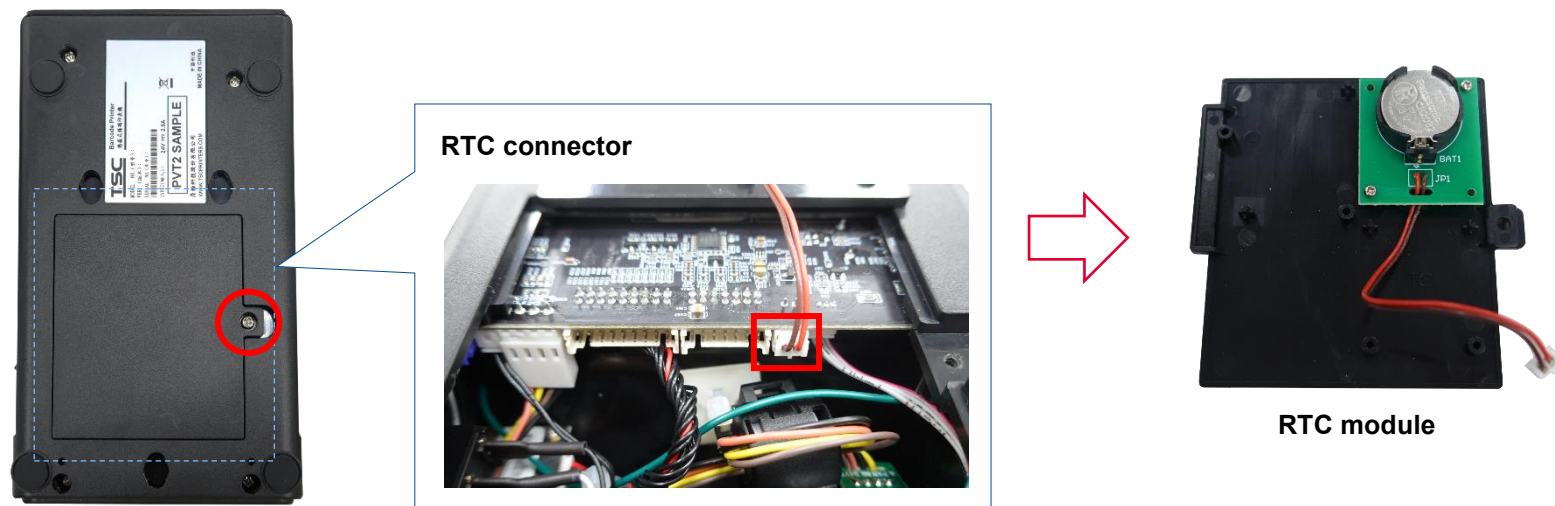

3. Connect the black end of Wi-Fi cable to Wi-Fi module and install the RTC battery on Wi-Fi module.

**Note: RTC battery (CR2032) is not included in the wireless module kit.**

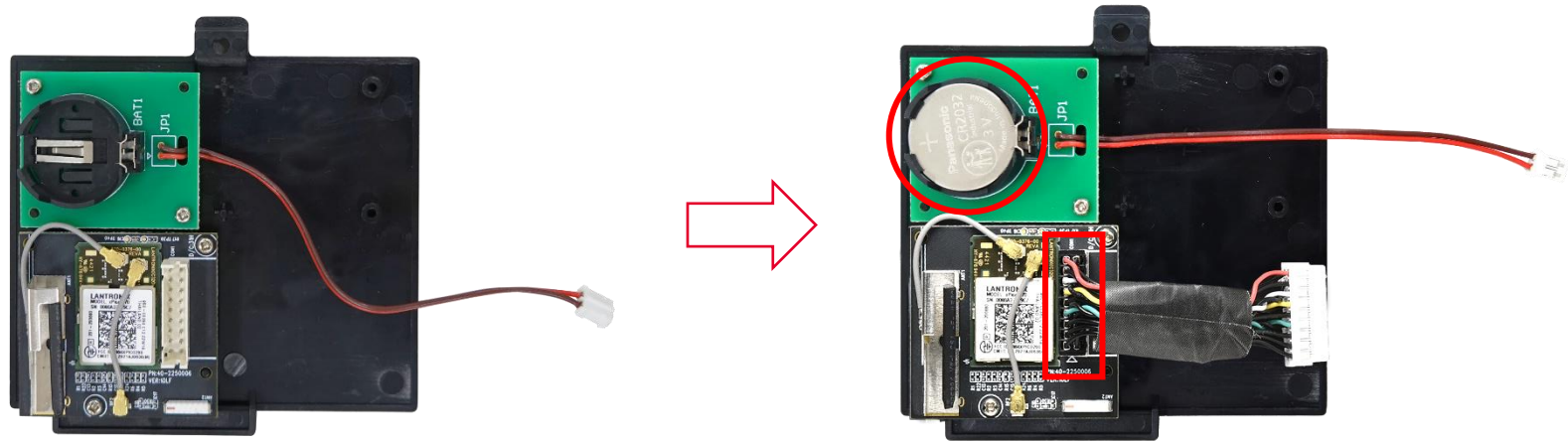

4. Connect another side of Wi-Fi cable and RTC cable into the main board. Install the Wi-Fi module to the bottom of the printer with one screw.

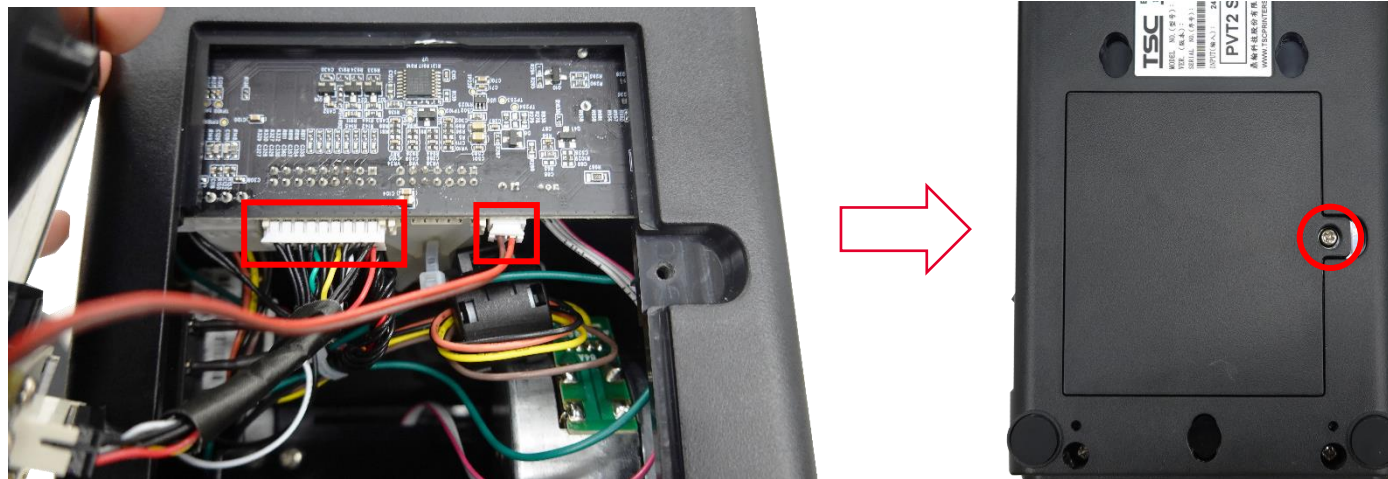

5. For LED version printer, refer to [Replacing the Top Cover](#) to stick the NFC tag on the LED top cover.  
For LCD version printer, refer to [Replacing the Control Panel Assembly](#) to stick the NFC tag on the LCD module bracket.



6. Reassemble the parts in the reverse procedures.



## 3.16 Installing the Cutter Module

1. Follow the steps in [Before You Begin](#) to prepare the printer.
2. Open the top cover to remove the lower front panel as shown.

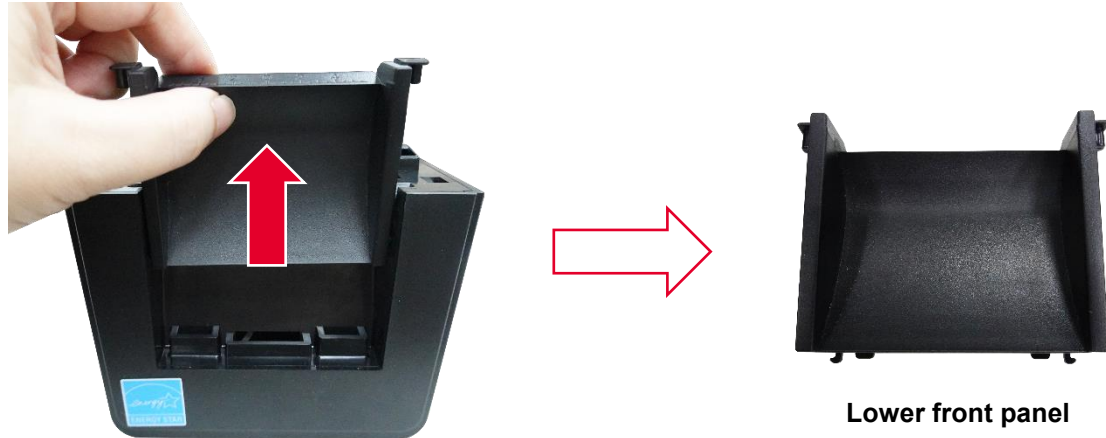

3. Thread the module's cables through the opening on the front side of the printer.



4. Press down to install the module ensuring that the ribs on the module are correctly inserted into the indicated openings.

**Note:**

**Make sure that the cable is fed completely into the printer and that the cable is not pressed during installation.**

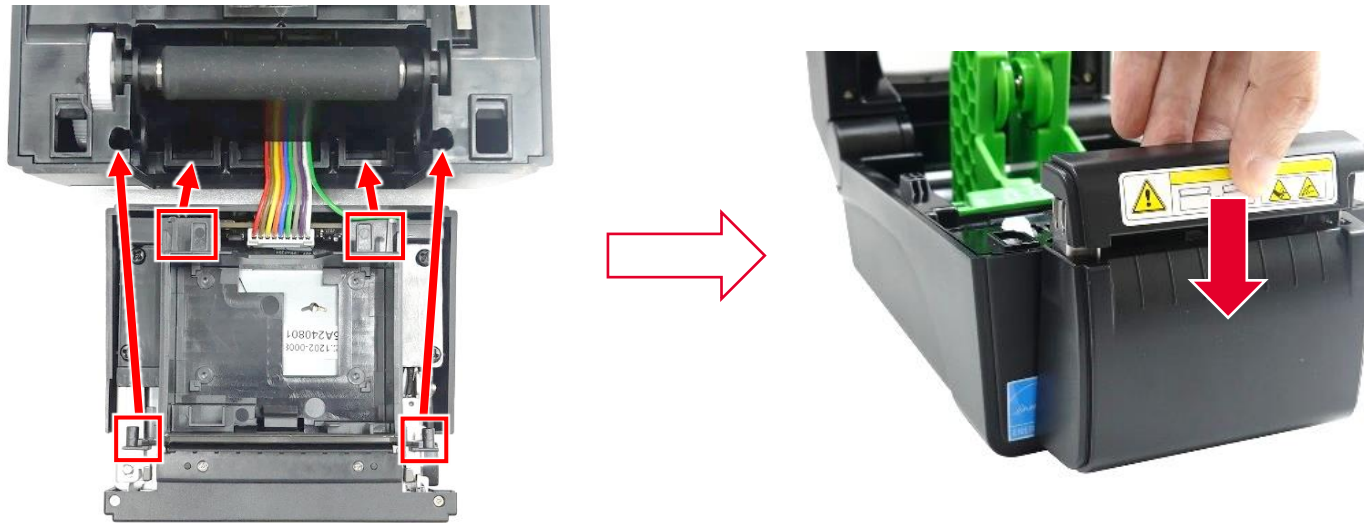

5. Remove one screw securing the RTC module cover in place and then open the cover. Connect the module's cable harness to the connector on the main board.

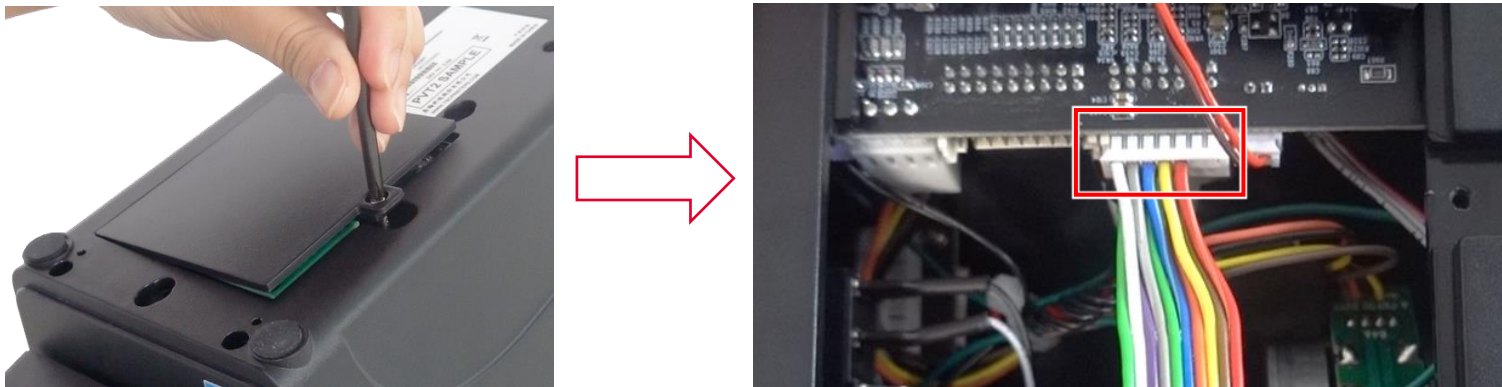

6. Reassemble the RTC module cover and install the single screw to secure the cover in place.



## 3.17 Installing the Peel-off Module

1. Follow the steps in [Before You Begin](#) to prepare the printer.
2. Open the top cover to remove the lower front panel as shown.

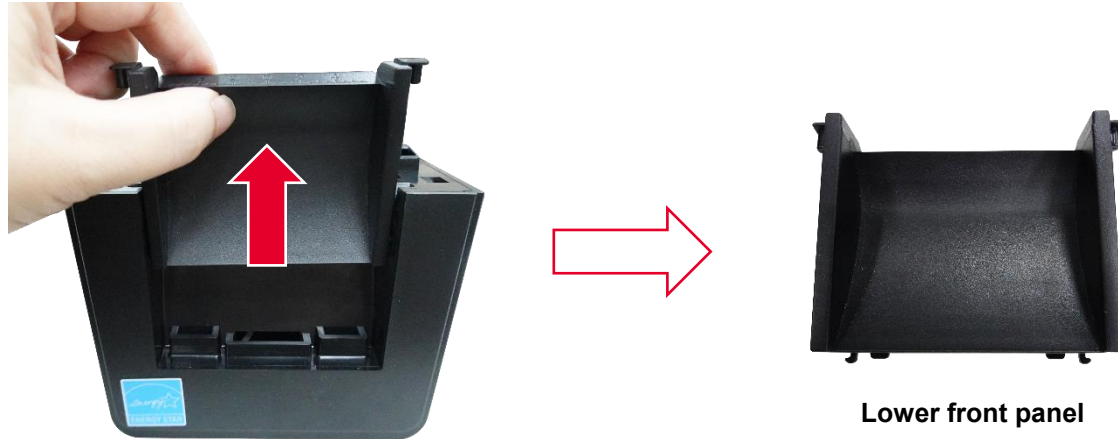

3. Open the peel roller.

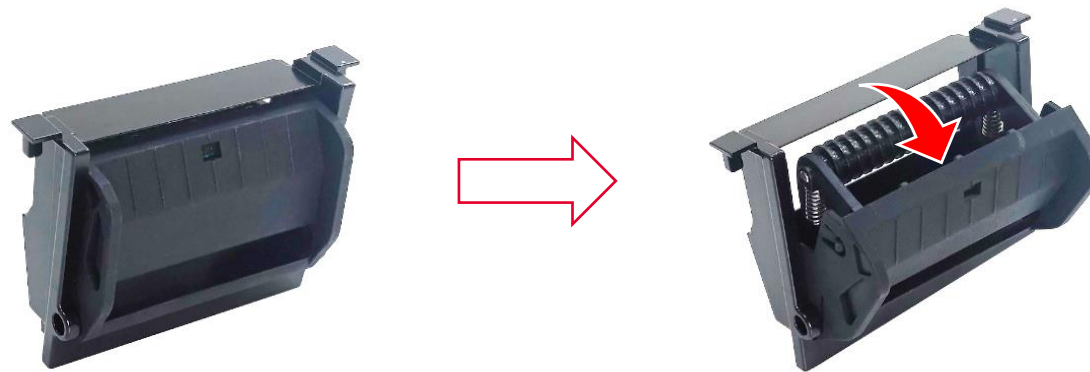

4. Thread the module's cable through the opening on the front side of the printer.



5. Press down to install the module ensuring that the ribs on the module are correctly inserted into the indicated openings. Close the peel roller.

**Note:**  
Make sure that the cable is fed completely into the printer and that the cable is not pressed during installation.

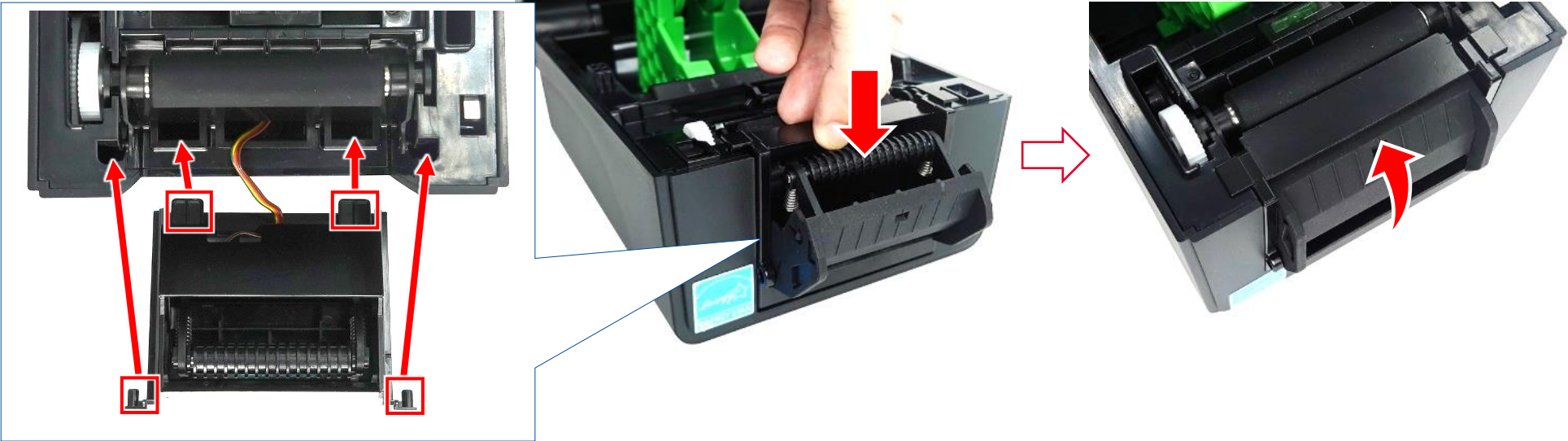

6. Turn the printer upside down to remove the screw securing the RTC module cover in place and then open the cover. Connect the module's cable harness to the connector on the main board.



7. Reassemble the RTC module cover and install the single screw to secure the cover in place.

# 3.18 Installing the Linerless Tear/Cutter Module



- 1. Linerless cutter
- 2. Linerless tear
- 3. Label tray
- 4. Linerless platen roller

- 1. Follow the steps in [Before You Begin](#) to prepare the printer.
- 2. Refer to [Replacing the Platen Roller Assembly](#) to replace the roller with the linerless roller (white).

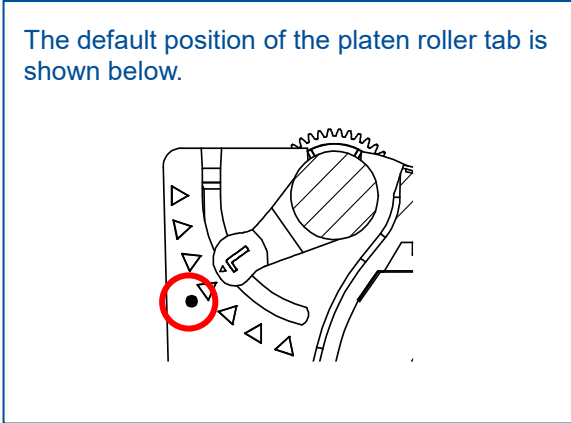

3. Thread the linerless module's cable through the opening on the front side of the printer.

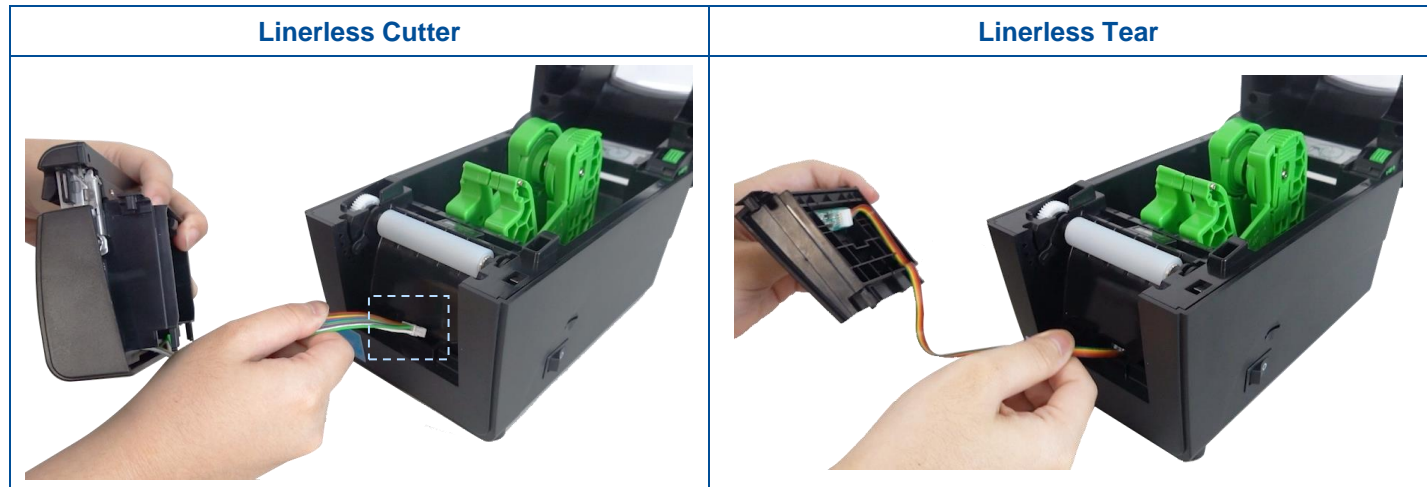

4. Press down to install the linerless module ensuring that the ribs on the module are correctly inserted into the indicated openings.

**Note:**

**Make sure that the cable is fed completely into the printer and that the cable is not pressed during installation.**

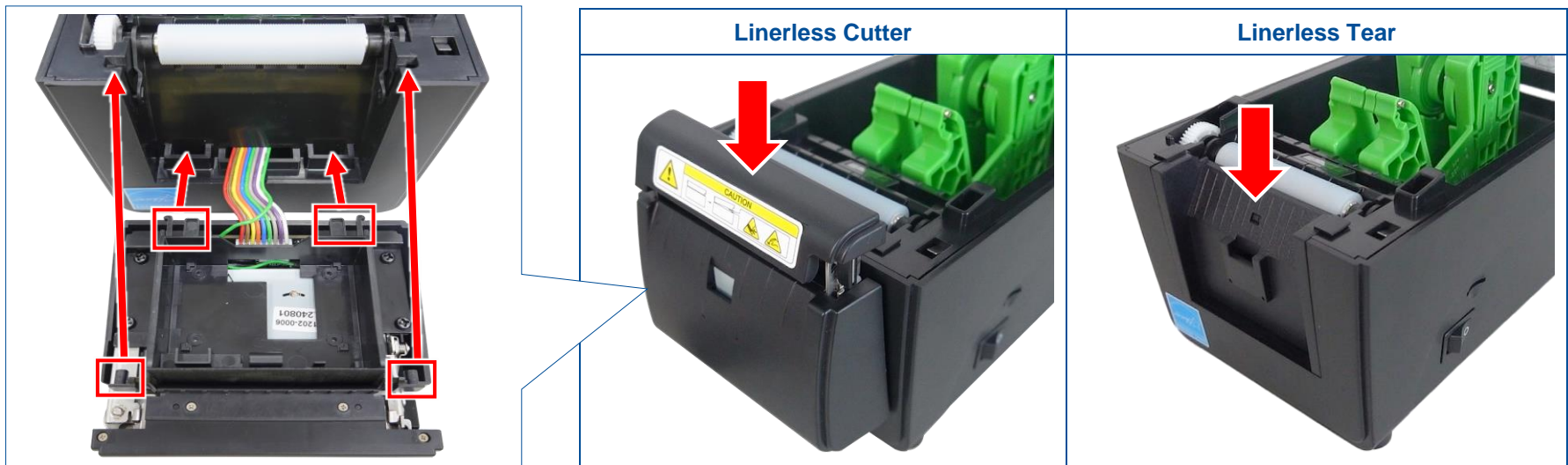



5. Remove the single screw securing the RTC module cover in place and then open the cover. Connect the linerless module's cable to the connector on the main board.

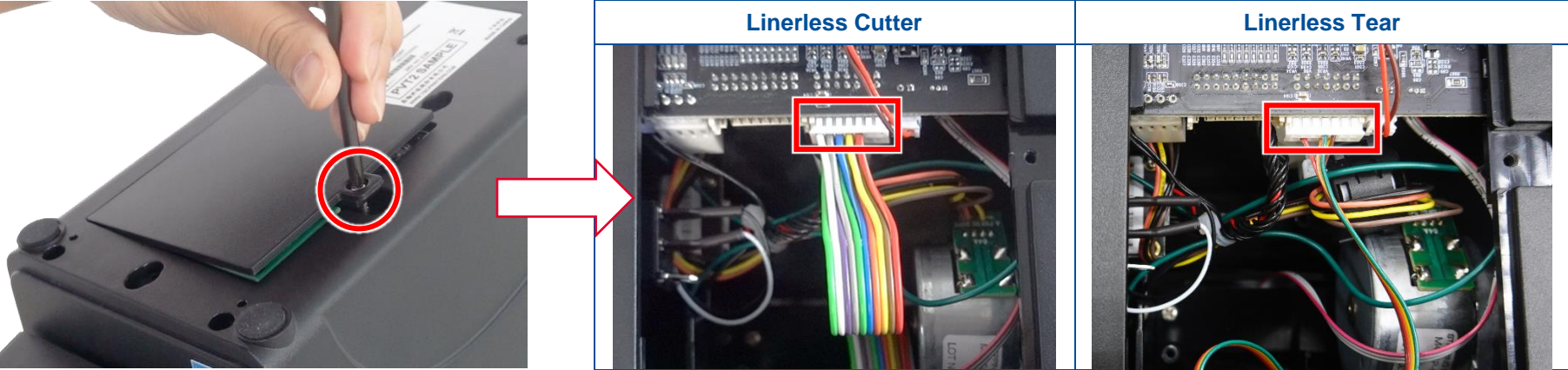

6. Install the label tray onto the linerless module.

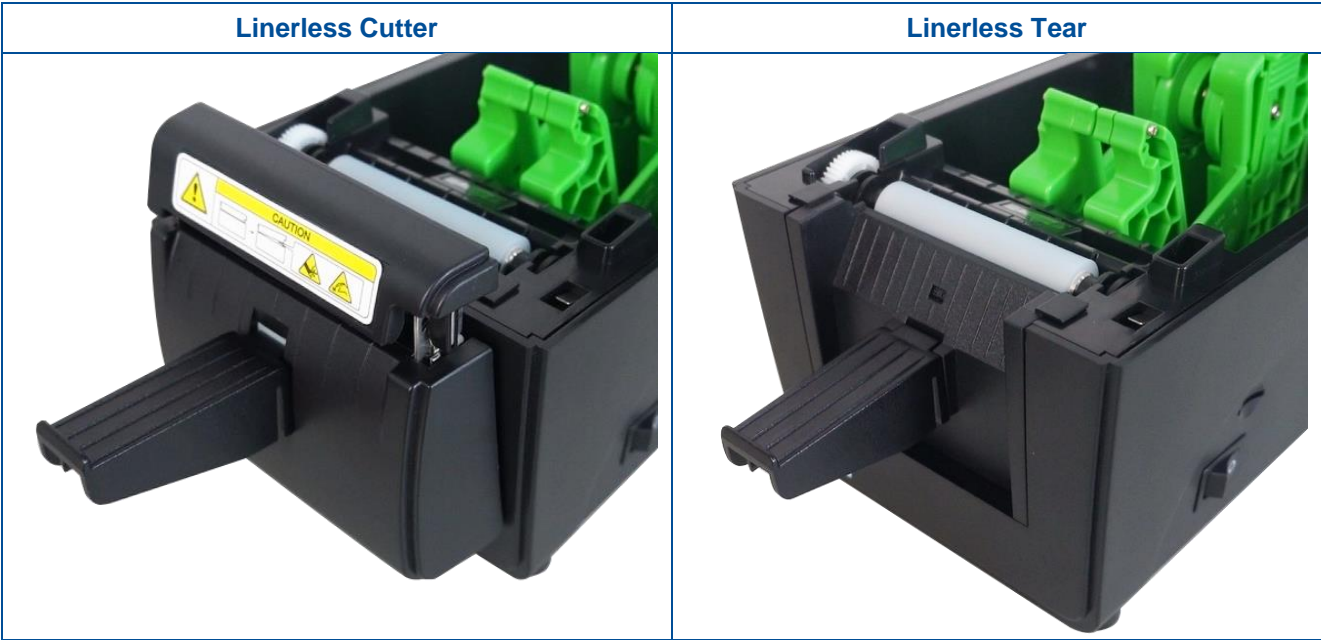

# 3.19 Installing the Narrow Media Adaptor

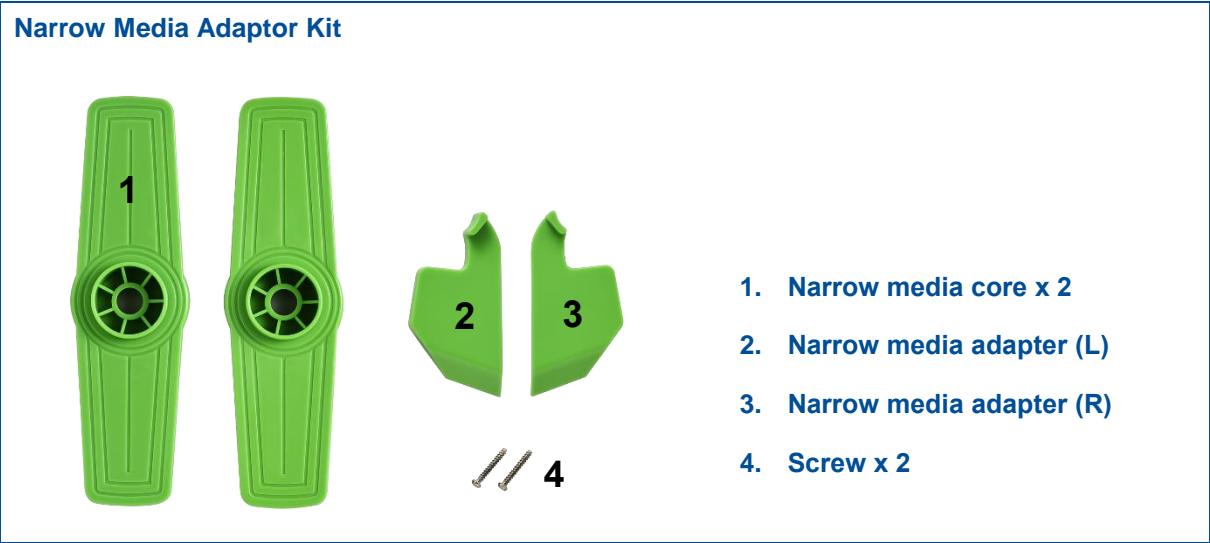

1. Open the printer's top cover and separate the media holders, then press down the media holder lock switch to fix the media holder. Remove the two screws on media holder as shown to remove both side of media cores.





2. Secure the narrow media cores on both side of media holder with the two screws.

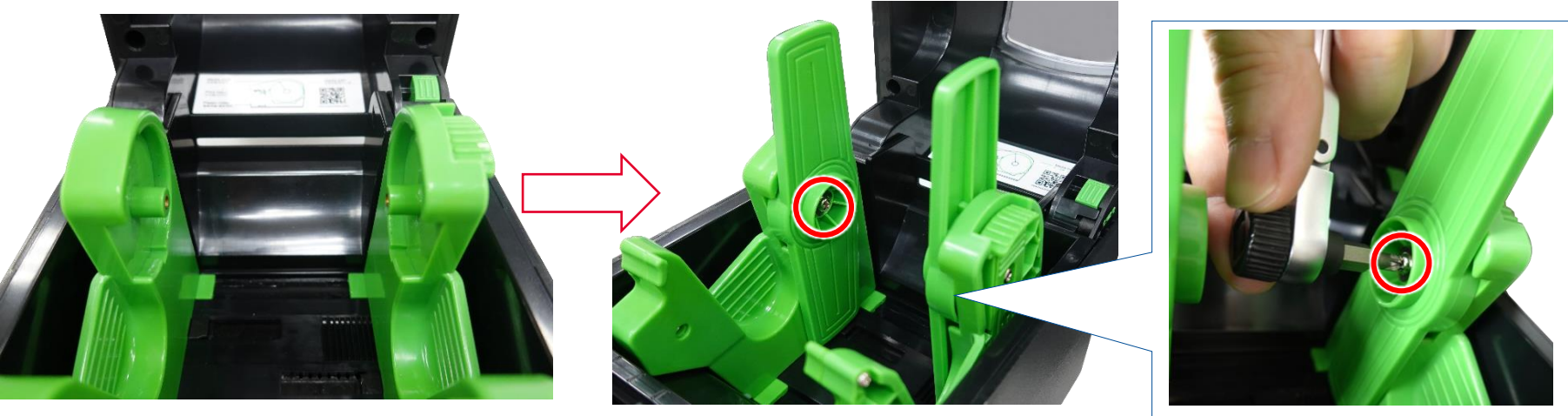

3. Remove the two screws on front of media holder as shown to remove both side of media guides.

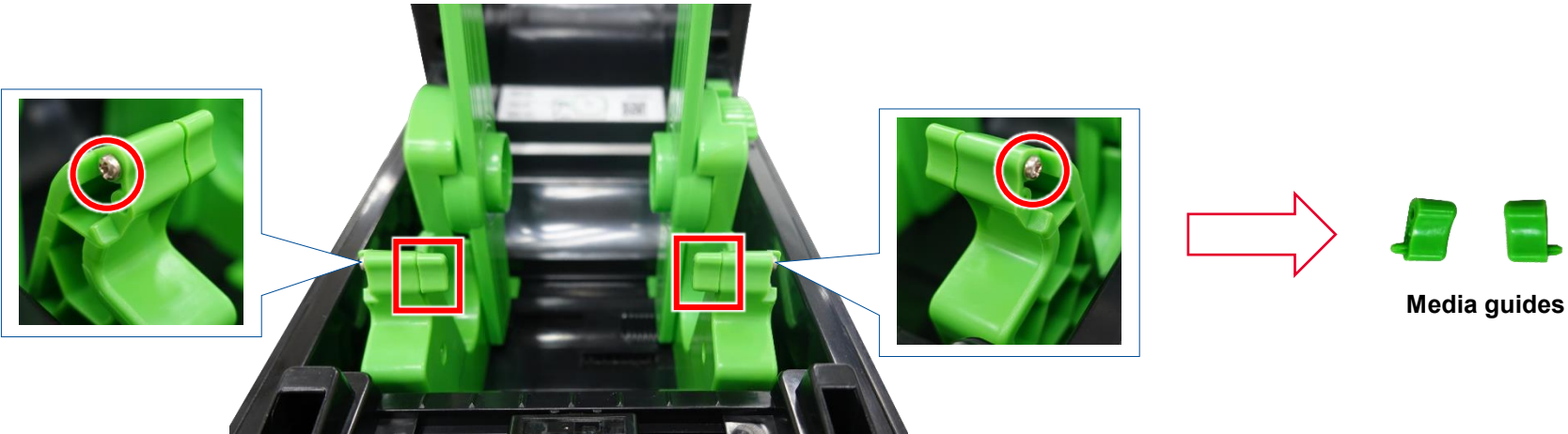

4. Secure the two narrow media adapters inside the media guide with the two screws.

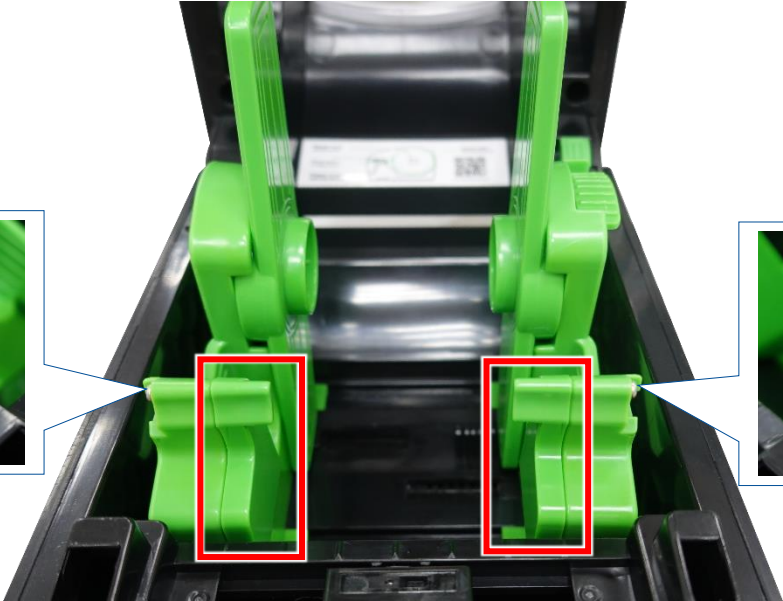
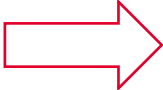

# 4 Troubleshooting

## 4.1 Common Problems

Problem	Possible Cause	Recovery Procedure
<b>Power indicator/ LCD does not illuminate</b>	The power cord is not properly connected.	<ul style="list-style-type: none"> <li>• Plug the power cord in printer and outlet.</li> <li>• Switch the printer on.</li> </ul>
<b>LED turn on (Carriage Open)</b>	The printer head is open.	Please close the print carriages.
<b>Not Printing</b>	<ul style="list-style-type: none"> <li>• Check if interface cable is well connected to the interface connector.</li> <li>• Check if wireless or Bluetooth device is well connected between host and printer.</li> <li>• The port specified in the Windows driver is not correct.</li> </ul>	<ul style="list-style-type: none"> <li>• Re-connect cable to interface or change a new cable.</li> <li>• If using serial cable,               <ul style="list-style-type: none"> <li>- Please replace the cable with pin to pin connected.</li> <li>- Check the baud rate setting. The default baud rate setting of printer is 9600,n,8,1.</li> </ul> </li> <li>• If using the Ethernet cable,               <ul style="list-style-type: none"> <li>- Check if the Ethernet RJ-45 connector green LED is lit on.</li> <li>- Check if the Ethernet RJ-45 connector amber LED is blinking.</li> <li>- Check if the printer gets the IP address when using DHCP mode.</li> <li>- Check if the IP address is correct when using the static IP address.</li> <li>- Wait a few seconds let the printer get the communication with the server</li> </ul> </li> </ul>

Problem	Possible Cause	Recovery Procedure
		<p>then check the IP address setting again.</p> <ul style="list-style-type: none"> <li>• Please reset the wireless device setting.</li> <li>• Select the correct printer port in the driver.</li> <li>• Print head's harness connector is not well connected with printhead. Turn off the printer and plug the connector again.</li> <li>• Check your program if there is a command PRINT at the end of the file and there must have CRLF at the end of each command line.</li> </ul>
<b>No Paper</b>	<ul style="list-style-type: none"> <li>• Running out of label.</li> <li>• The label is installed incorrectly.</li> <li>• Gap/black mark sensor is not calibrated.</li> </ul>	<ul style="list-style-type: none"> <li>• Supply a new label roll.</li> <li>• Reinstall the label roll.</li> <li>• Calibrate the gap/black mark sensor.</li> </ul>
<b>Paper jam</b>	<ul style="list-style-type: none"> <li>• Gap/black mark sensor is not set properly.</li> <li>• Make sure label size is set properly.</li> <li>• Labels may be stuck inside the printer mechanism.</li> </ul>	<ul style="list-style-type: none"> <li>• Calibrate the media sensor.</li> <li>• Set media size correctly.</li> <li>• Remove the stuck label inside the printer mechanism.</li> </ul>
<b>Can't downloading the file to memory (FLASH / CARD)</b>	The space of memory is full.	Delete unused files in the memory.
<b>SD card is unable to use</b>	<ul style="list-style-type: none"> <li>• SD card is damaged.</li> <li>• SD card doesn't insert correctly.</li> </ul>	<ul style="list-style-type: none"> <li>• Use the supported capacity SD card.</li> <li>• Insert the SD card again.</li> </ul>

Problem	Possible Cause	Recovery Procedure
	<ul style="list-style-type: none"> <li>Use the non-approved SD card manufacturer.</li> </ul>	
<b>Poor Print Quality</b>	<ul style="list-style-type: none"> <li>Media is loaded incorrectly.</li> <li>Dust or adhesive accumulation on the print head.</li> <li>Print density is not set properly.</li> <li>Print head element is damaged.</li> <li>The print head pressure is not set properly.</li> </ul>	<ul style="list-style-type: none"> <li>Reload the supply.</li> <li>Clean the print head.</li> <li>Clean the platen roller.</li> <li>Adjust the print density and print speed.</li> <li>Run printer self-test and check the print head test pattern if there is dot missing in the pattern.</li> <li>The release lever does not latch the print head properly.</li> </ul>
<b>Missing printing on the left or right side of label</b>	Wrong label size setup.	Set the correct label size.
<b>Gray line on the blank label</b>	<ul style="list-style-type: none"> <li>The print head is dirty.</li> <li>The platen roller is dirty.</li> </ul>	<ul style="list-style-type: none"> <li>Clean the print head.</li> <li>Clean the platen roller.</li> </ul>
<b>Irregular printing</b>	<ul style="list-style-type: none"> <li>The printer is in Hex Dump mode.</li> <li>The RS-232 setting is incorrect.</li> </ul>	<ul style="list-style-type: none"> <li>Turn off and on the printer to skip the dump mode.</li> <li>Re-set the Rs-232 setting.</li> </ul>
<b>Label feeding is not stable (skew) when printing</b>	The media guides do not touch the edge of the media.	<ul style="list-style-type: none"> <li>If the label is moving to the right side, please move the label guide to left.</li> <li>If the label is moving to the left side, please move the label guide to right.</li> </ul>

Problem	Possible Cause	Recovery Procedure
<b>Skip labels when printing</b>	<ul style="list-style-type: none"> <li>• Label size is not specified properly.</li> <li>• Sensor sensitivity is not set properly.</li> <li>• The media sensor is covered with dust.</li> </ul>	<ul style="list-style-type: none"> <li>• Check if label size is setup correctly.</li> <li>• Calibrate the sensor by Auto Gap or Manual Gap options.</li> <li>• Clear the GAP/Black mark sensor by blower.</li> </ul>
<b>RTC time is incorrect when reboot the printer</b>	The battery has run down.	Check if there is a battery on the main board.
<b>The left side printout position is incorrect</b>	<ul style="list-style-type: none"> <li>• Wrong label size setup.</li> <li>• The parameter Shift X in printer is incorrect.</li> </ul>	Set the correct label size.
<b>The printing position of small label is incorrect</b>	<ul style="list-style-type: none"> <li>• Media sensor sensitivity is not set properly.</li> <li>• Label size is incorrect.</li> <li>• The parameter Shift Y is incorrect.</li> <li>• The vertical offset setting in the driver is incorrect.</li> </ul>	<ul style="list-style-type: none"> <li>• Calibrate the sensor sensitivity again.</li> <li>• Set the correct label size and gap size.</li> <li>• Enter LCD menu (or via TSC Console) to fine tune the parameter of Shift Y.</li> <li>• If using the software BarTender, please set the vertical offset in the driver.</li> </ul>

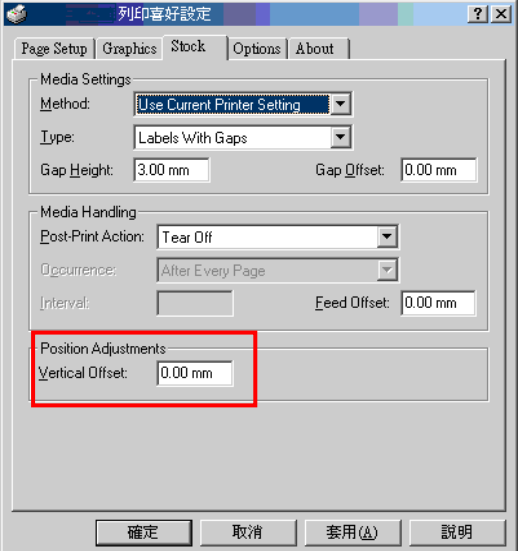

Problem	Possible Cause	Recovery Procedure
		 <p>The screenshot shows the '列印喜好設定' (Print Preferences) dialog box with the following settings:</p> <ul style="list-style-type: none"><li>Method: Use Current Printer Setting</li><li>Type: Labels With Gaps</li><li>Gap Height: 3.00 mm</li><li>Gap Offset: 0.00 mm</li><li>Post-Print Action: Tear Off</li><li>Occurrence: After Every Page</li><li>Interval: (empty)</li><li>Feed Offset: 0.00 mm</li><li>Position Adjustments: Vertical Offset: 0.00 mm</li></ul> <p>The 'Position Adjustments' section, including the 'Vertical Offset' field, is highlighted with a red box.</p>

# 5 Maintenance

This session presents the clean tools and methods to maintain the printer.

## ■ For Cleaning

Depending on the media used, the printer may accumulate residues (media dust, adhesives, etc.) as a by-product of normal printing. To maintain the best printing quality, you should remove these residues by cleaning the printer periodically. Regularly clean the print head and supply sensors once change a new media to keep the printer at the optimized performance and extend printer life.

## ■ For Disinfecting

Sanitize your printer to protect yourself and others and can help prevent the spread of viruses.

## ■ Important

- Set the printer power switch to O (Off) prior to performing any cleaning or disinfecting tasks. Leave the power cord connected to keep the printer grounded and to reduce the risk of electrostatic damage.
- Do not wear rings or other metallic objects while cleaning any interior area of the printer.
- Use only the cleaning agents recommended in this document. Use of other agents may damage the printer and void its warranty.
- Do not spray or drip liquid cleaning solutions directly into the printer. Apply the solution on a clean lint-free cloth and then apply the dampened cloth to the printer.
- Do not use canned air in the interior of the printer as it can blow dust and debris onto sensors and other critical components.
- Only use a vacuum cleaner with a nozzle and hose that are conductive and grounded to drain off static build up.
- All reference in these procedures for use of isopropyl alcohol requires that a 99% or greater isopropyl alcohol content be used to reduce the risk of moisture corrosion to the printhead.
- Do not touch printhead by hand. If you touch it carelessly, please use 99% Isopropyl alcohol to clean it.

- Always taking personal precaution when using any cleaning agent.

## Cleaning Tools:

- Cotton swab
- Lint-free cloth
- Brush with soft non-metallic bristles
- Vacuum cleaner
- 75% Ethanol (for disinfecting)
- 99% Isopropyl alcohol (for printhead and platen roller cleaning)
- Genuine printhead cleaning pen
- Mild detergent (without chlorine)

## Cleaning Process:

Printer Part	Method	Interval
<b>Print Head</b>	<ol style="list-style-type: none"> <li>I. Always turn off the printer before cleaning the printhead.</li> <li>II. Allow the printhead to cool for at least one minute.</li> <li>III. Use a cotton swab and 99% Isopropyl Alcohol or genuine print head cleaning pen to clean the print head surface.</li> </ol>	Clean the print head when changing a new label roll.
<b>Platen Roller</b>	<ol style="list-style-type: none"> <li>I. Turn off the printer.</li> <li>II. Rotate the platen roller and wipe it thoroughly with the lint-free 99% Isopropyl Alcohol.</li> </ol>	Clean the platen roller when changing a new label roll
<b>Peel Bar</b>	Use the lint-free cloth with 99% Isopropyl Alcohol to wipe it.	As needed

Printer Part	Method	Interval
<b>Sensor</b>	<p>Use brush with soft non-metallic bristles or a vacuum cleaner, to remove paper dust.</p> <p>Clean upper and lower media sensors to ensure reliable Top of Form and Paper Out sensing.</p>	Monthly
<b>Exterior</b>	<p>Clean the exterior surfaces with a clean, lint-free cloth (water-dampened cloth). If necessary, use a mild detergent or desktop cleaning solution then use the 75% Ethanol to wipe it.</p>	As needed
<b>Interior</b>	<p>Clean the interior of the printer by removing any dirt and lint with a vacuum cleaner, as described above, or use a brush with soft non-metallic bristles then use the 75% Ethanol to wipe it.</p>	As needed
<b>Linerless Printer</b>	<p>Please refer to <a href="#">Linerless Cleaning Kit User Manual</a> for more information.</p> 	<ul style="list-style-type: none"> <li>◆ Clean as needed or after printing every 1 km.</li> <li>◆ Please determine the maintenance intervals based on actual usage.</li> </ul>

# Revise History

Date	Content	Editor
2023/11/6	First release	Camille
2024/3/12	Modify the "Maintenance" section (add the linerless cleaning info.)	Camille



[www.tscprinters.com](http://www.tscprinters.com)